

[Ensta Paris | 8 Décembre 2022]

Dynamique Start-Up & Projets quantique

Région
île de France

PARIS
SACLAY
Communauté d'agglomération

ENSTA

IP PARIS

NAFEMS

Teratec



Digital
Engineering

9h30 – Mot d’accueil

- Sylvain Ferrari – Directeur adjoint – ENSTA Paris
- Jean-Luc Beylat – Président – Systematic Paris-Région
- Daniel Verwaerde – Président – Teratec

9h55 – Ouverture

- Philippe Duluc – Président Hub “Digital Engineering”

10h00 – Allocution

- Alexandra Dublanche – Vice-Président Région Ile-de-France

10h15 – Présentation projet FetQ/Qarbone

- Juliette Ginies – Chief of Staff C12

10h45 – Présentation projet Qryolink

- Théau Peronnin – CEO Alice & Bob

Pause

11h30 – Présentation des actualités récentes de Pasqal et des projets partenariaux

- Christophe Legrand – SVP Global Business Development Pasqal

12h00 – Présentation projets UFOQO, SLQT, ROQC

- Jean Senellart – Chief Product Officer Quandela

12h30 – Présentation projet Eduquantum

- Sylvain Ferrari – Directeur adjoint – ENSTA Paris
- Davide Boschetto – Professeur ENSTA Paris

13h00 – Pause déjeuner

14h00 – Présentation projet Vulqain

- Laurent Guiraud – Co-fondateur Colibrिटd

14h30 – Présentation projet ParisRegionQCI

- Thomas Rivera – PhD Research Project Manager Orange

15h00 – Positionnement des Appels à Projets Publics

- Neil Abroug – Coordinateur National quantique

15h15 – Présentations des Appels à Projets quantique

- Emmanuelle Vergnaud – Directrice des opérations Teratec
- Thierry Louvet – Directeur Europe & International Systematic
- Esther Slamitz – Coordinatrice du Hub “Digital Engineering” Systematic

15h30 Présentation projet QEI

- Olivier Ezratty

15h40 – Pitch compétences/ Pitch idées de projets

17h00 – Conclusion

- Christian Saguez – Président d’honneur – Teratec

[Mot d'accueil]



Sylvain Ferrari
Directeur Adjoint
ENSTA Paris



Jean-Luc Beylat
Président
Systematic



Daniel Verwaerde
Président
Teratec



François Large
Gérant
Nafems



Philippe Duluc
Président

Hub « Digital Engineering » Systematic

Axes technologiques prioritaires

Ingénierie Système & logicielle

HPC

Evolution sous l'effet de plusieurs forces

- Nouveaux usages : IA, IoT ou temps réel
- Architectures hybrides : accélérateurs ou en réseau Edge Computing, Fog Computing,...
- Plus grande productivité de développement
- Baisse du coût du calcul : démocratisation du HPC

Mutation rapide qui soulève deux enjeux

- Amélioration des fondamentaux du HPC
- Soutien à la diffusion des nouveaux usages du HPC

Quantum

Veille technologique

- Calcul quantique adiabatique
- Calcul par circuits quantiques
- Simulation hamiltonienne

Usecases

- Algorithmes et accélération quantiques
- Plateformes de programmation et simulation
- Applications métiers

Roadmaps

- Architecture de calcul à qubits logiques
- Architecture de calcul à qubits physiques (NISQ)
- Simulation quantique

Simulation

Représentativité des modèles

- Matériaux, multi-échelles, couplage multi-physique, procédés de fabrication
- Verrous : composites, forgeage, fonderie, emboutissage structures minces, injection polymères thermoplastiques, usinage à grande vitesse, assemblages de fabrication additive...

Allègement des modèles

- Réduction formelle de complexité, méthodes d'analyse de données

Conception système optimale

- Calcul de variation et de fonctions non explicites, recherche d'optimum
- Caractérisation des incertitudes et lien avec une maquette numérique
- Gestion des résultats de simulation en grappe (en lien avec le PLM)

Mise en œuvre et organisation

- Automatisation lien CAO-calcul, exploitation et capitalisation des résultats, data mining, réalité virtuelle et analyse, intégration dans le PLM étendu...

Maîtrise de la complexité et de ses nouvelles formes

Gestion des comportements probabilistes et des incertitudes, simulation hybride discret-continu et multi-échelle, ingénierie de ligne de produits et système-de-systèmes, introduction de l'intelligence artificielle dans les outils d'ingénierie système, et démocratisation des méthodes formelles.

Vers une disparition de la frontière entre développement et opération

DevOps au niveau système, continuité numérique, et jumeau numérique d'ingénierie.

Au sujet des évolutions technologiques des outils-

Souveraineté, travail collaboratif, outils autonomes, accessibilité, fédération des univers de données d'ingénierie, sécurité des collaborations, et frugalité des environnement numérique d'ingénierie.

Focus Quantique

Les périmètres techniques / Roadmaps

- Architecture de calcul à qubits logiques
- Architecture de calcul à qubits physiques (NISQ)
- Simulation quantique

Projets accompagnés & labelisés

- 25 projets Quantique accompagnés
- dont 14 financés
 - 5 computing
 - 2 télécoms
 - 2 crypto
 - 3 lasers cascades quantiques
- Projets emblématiques

Levées de fonds

			
25 M€	10 M€	15 M€	30 M€

Thématique commune à 3 Hubs

- Digital Engineering
- Optics & Photonics
- Cybers & Security
- Digital Infrastructure & IOT

Cartographie des acteurs de l'écosystème

LE QUANTIQUE
CHEZ LES MEMBRES
DE SYSTEMATIC

De l'émission de photon à l'internet quantique,
les membres de Systematic vous proposent **briques technologiques**
& **cas d'usages** pour cette nouvelle révolution Deep Tech !



Février 2022

Sources	Sources de qubits photoniques	Lasers
Transmission	Transmission optique	Internet quantique
Capteurs	Capteurs quantiques / Métrologie	
Traitement	Générateur de nombres aléatoires	Circuits photoniques intégrés / Wafers
Informatique quantique	Semiconducteur	
Informatique quantique	Calcul quantique	

R&D quantique
Simulation
Utilisateurs (calculs intensifs)
Associations
Sécurité et cryptographie
Test
Infrastructures / Outils / cryogénie et atomes froids



Juliette Ginies
Chief of Staff
C12 Technologies

C12

Building scalable and ultra-coherent quantum computers with carbon nanotubes

Juliette Ginies, *Chief of Staff*

juliette@c12qe.com

DECEMBER 2022



SUMMARY

01 C12 in a nutshell

02 Our vision

03 Road to commercialization

04 Ongoing projects

01

C12 in a nutshell

Founded in 2020

Paris-based quantum hardware startup

Technology from the Ecole Normale Supérieure in Paris

30 employees

\$10m Seed round in July 2021

First application-specific chips for quantum chemistry in development

6 patents



02

Our vision

Errors come from defects in the qubit material

“A roadmap in 10 years, based on a solid-state qubit, relies on breakthroughs in material science.”

Chris Monroe, IonQ co-founder and chief scientist

We are
transforming
Carbon Nanotubes
into “quantum
transistors”

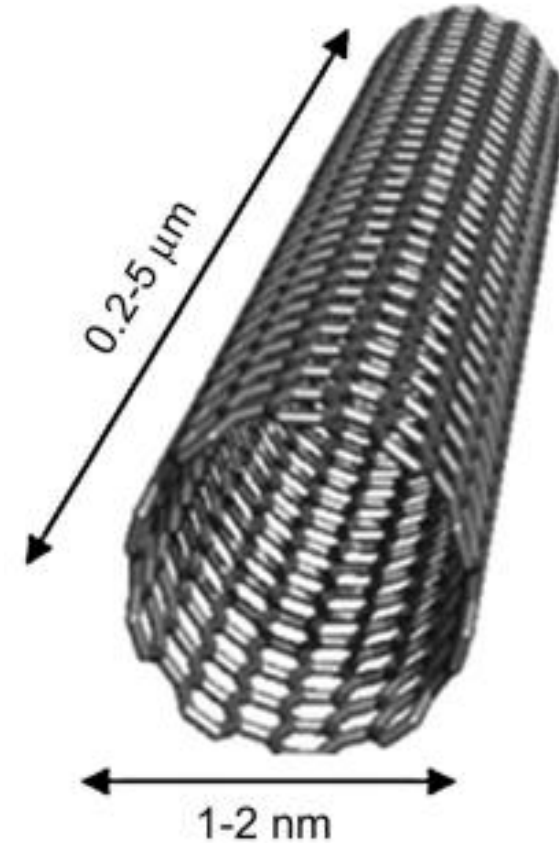

C12 has an **unique** approach to quantum computing

High-fidelity qubits

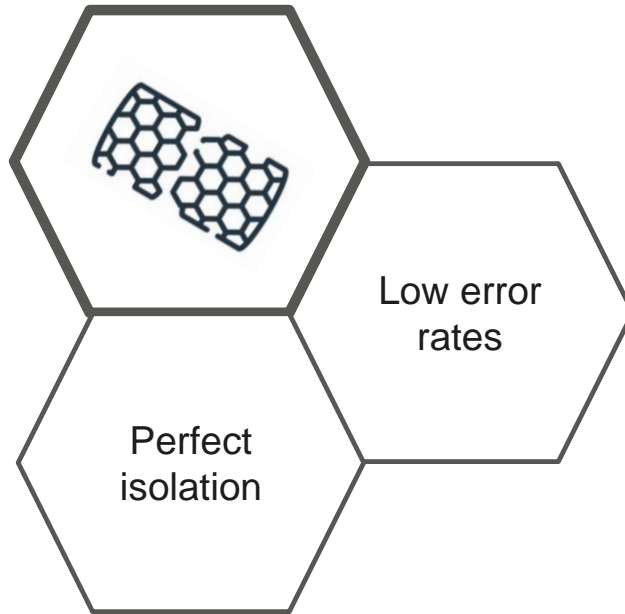

Qubits are hosted in **ultra-pure carbon nanotubes** to reduce environment-induced errors.

Scalable fabrication

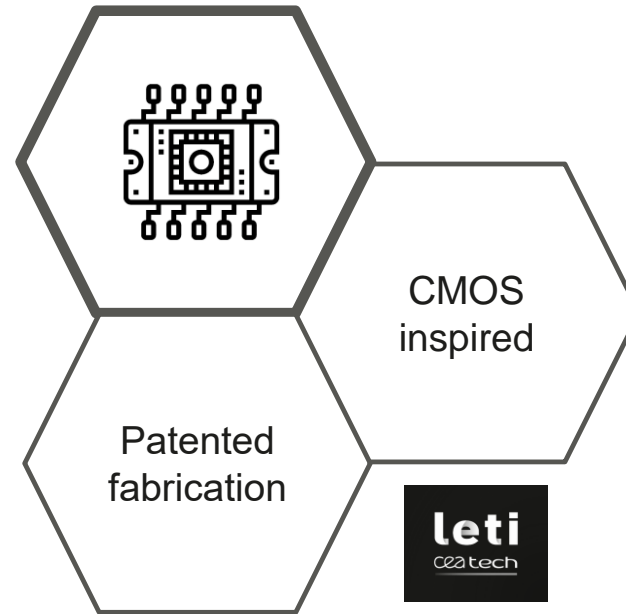

Proprietary **high-throughput assembly** technique compatible with semiconductor **fabrication**.

High connectivity

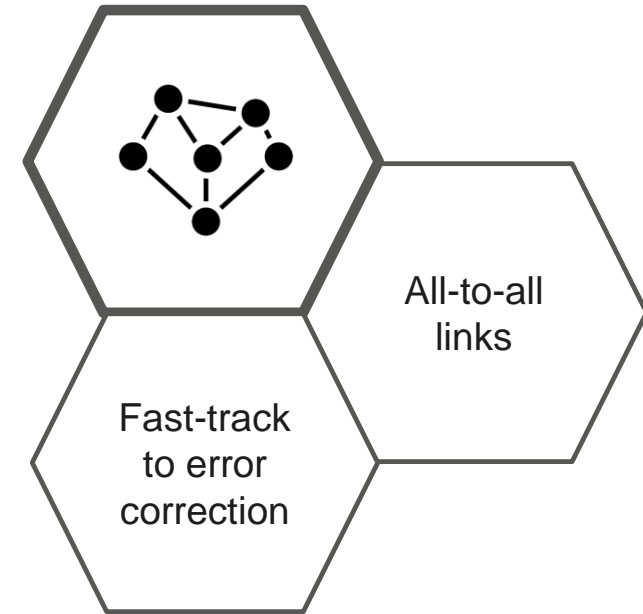

Customized quantum processor and **low overhead** for error correction.

03

Road to commercialization

Before error correction, there is a lot of value in **error reduction** to build **Noisy Intermediate-Scale Quantum** applications

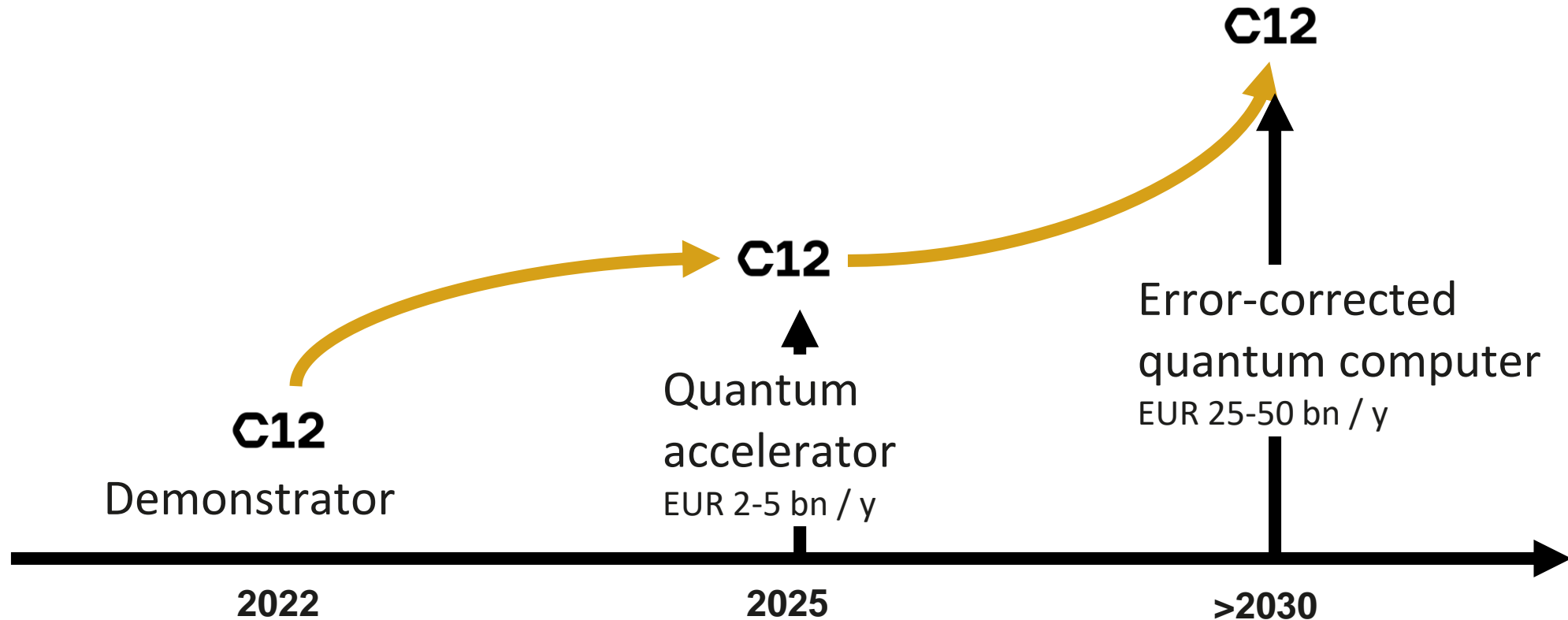

How to unlock industry applications? By developing **application-specific customized quantum processors**

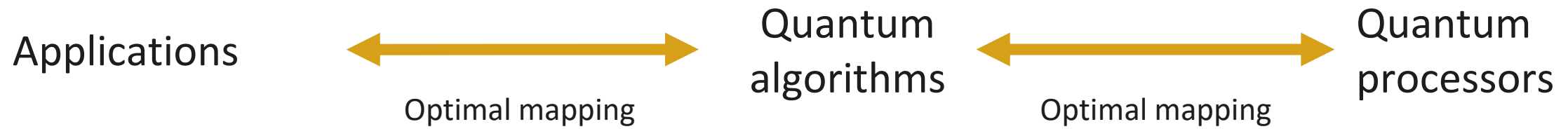

C12's product roadmap

Simulator

First-of-kind “**digital twin**” of future quantum processors

Advanced modelling of quantum physics phenomena

Available to test first quantum algorithms

Quantum chips

Co-design with selected partners

Application-specific quantum chip

Non recurring engineering costs

C12 is designing **application-specific quantum processors** for forward-thinking companies



Use case
identification

*Most suitable
application for
near-term
quantum
computers
Focus on highest
business impact*



Algorithms development &
test on quantum computer
simulator

*Problem statement
Optimal mapping
Co-optimization*



Development of chip layout

*Optimal mapping
Scaling*

04

Ongoing projects

We are developing first two **application-specific chips** with partners – at the same time, we work on our scalability

<p>PaQ OCH2Q</p> <p>Quantum chemistry</p> <p>Atomic layer deposition</p> <p>Quantum algorithm: Variational Quantum Eigensolver</p>		<p>Quarbone project</p> <p>Quantum optimization solver</p> <p>Graph-based combinatorial problems</p> <p>Quantum algorithm: Quantum Approximate Optimization Algorithm</p>		<p>FET-Q (under review)</p> <p>Fabrication à l'Echelle de Transistor Quantiques en carbone</p> <p>Objective to scale-up our fabrication process</p>
---	--	--	--	--



Quarbone project - Optimization

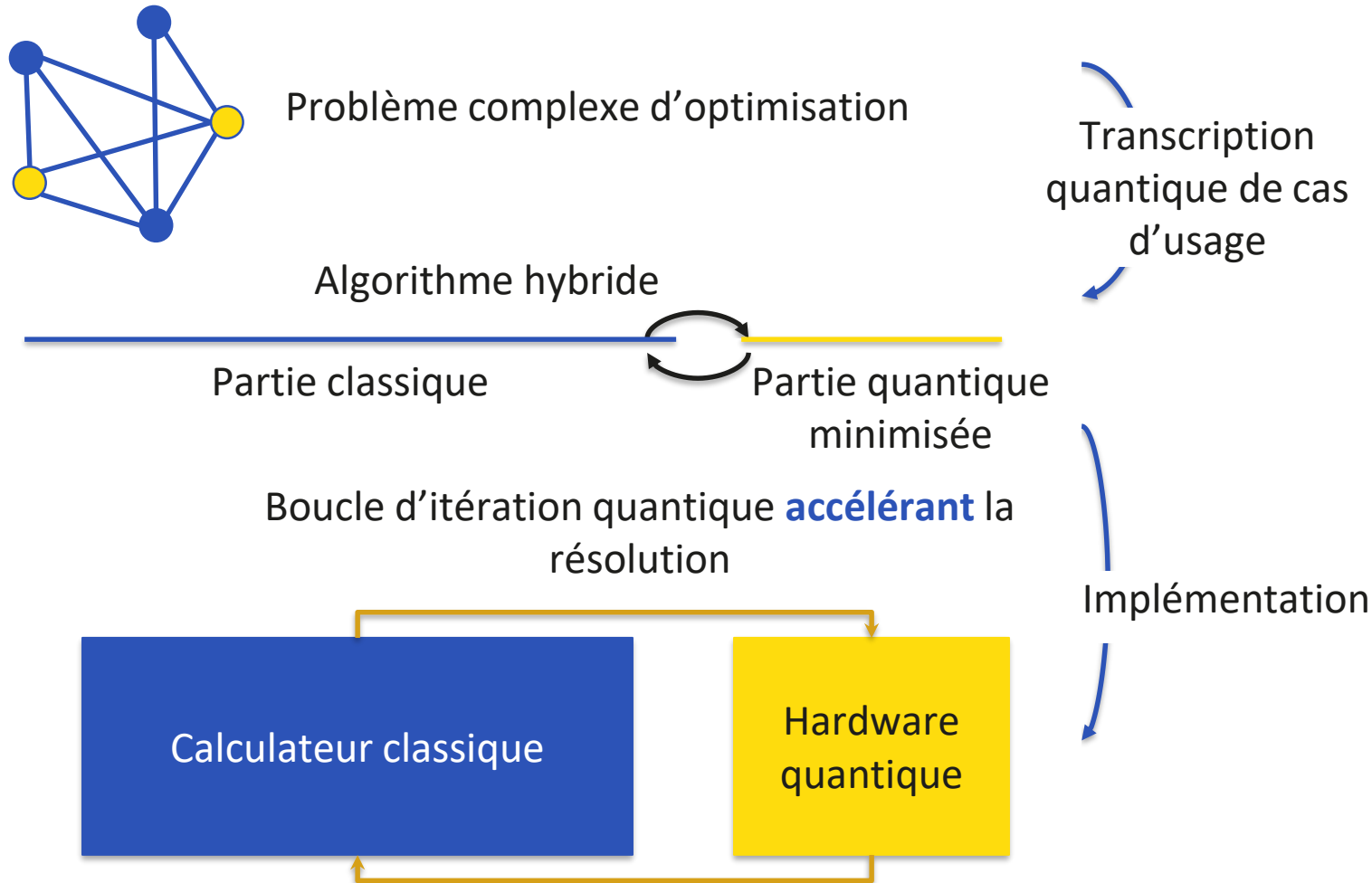

Objectif: un démonstrateur pour le marché du calcul quantique le plus court terme, le NISQ

- Processeur quantique **de haute fidélité** et qui pourra **passer à l'échelle**
- **Système entièrement intégré** autour de cette plateforme
- Algorithmes spécifiques **résolvant des problèmes industriels d'optimisation**, bénéficiant de **la haute connectivité** du processeur
- **Transformateur** pour de très nombreux secteurs (énergie, chimie, transports, pharma, finance)

Quarbone project - Optimization

C12

- Hardware
- Architecture application-specific
- API



- Caractérisation
- Sources des erreurs



- Cas d'usage industriels
- Transcription



- Middleware
- Compilation
- Standards d'intégration HPC

OCH2Q project - Quantum chemistry



- **Application:** optimize a critical chemical process (atomic layer deposition) for Air Liquide – High business impact
- **Algorithms:** Quantum algorithm produced by Cambridge Quantum using a Variational Quantum Eigensolver algorithm
- **Processor:** Use-case well adapted for the characteristics of our first quantum processors

FET-Q project: nous souhaitons passer à l'échelle, sur l'optimisation du matériau et la ligne de production

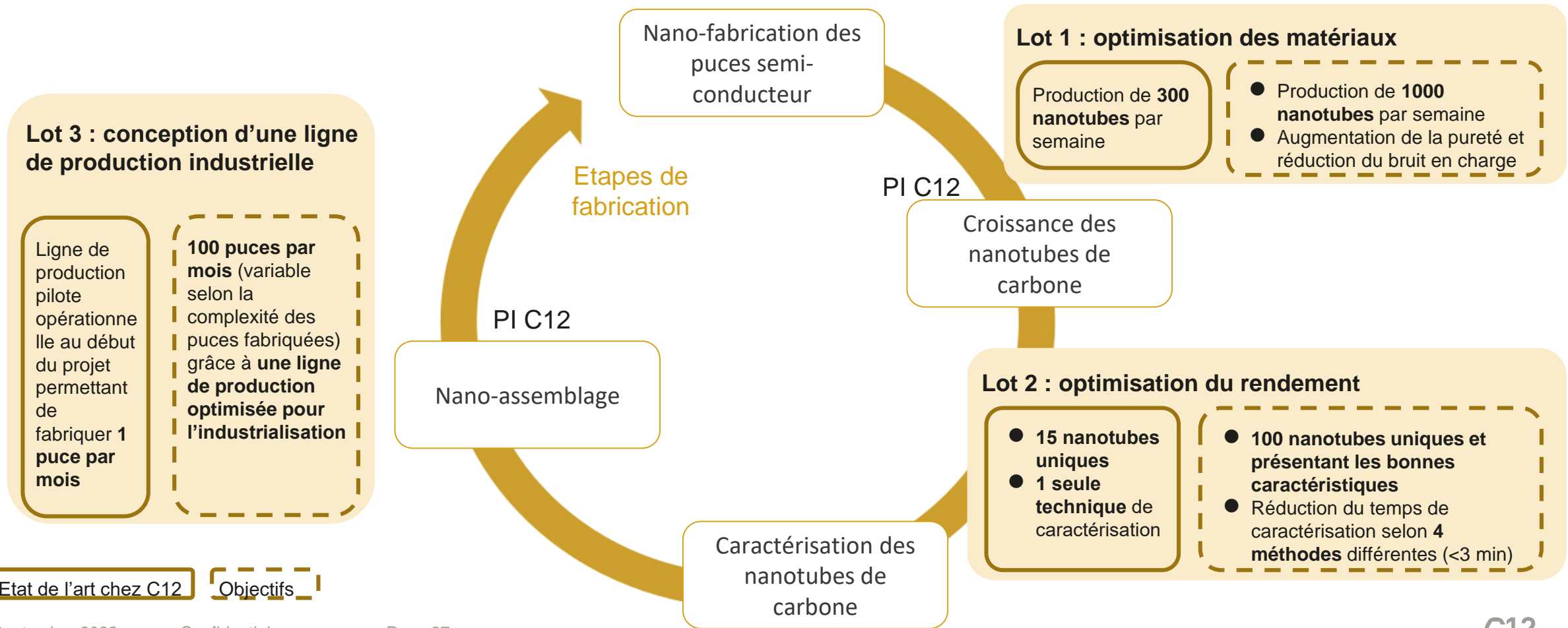

FET-Q project: les impacts de ce projet



- **Création d'emplois directs:**

9 sur la durée du projet, sur la région IDF qui travailleront sur le projet

- **Création d'emplois indirects:**

entre 10-15 par an chez C12 sur des postes industriels et de recherche grâce aux résultats du projet (pic en 2026 avec la ligne de production)



- **Dépôt de brevets:**

4 envisagés sur ce projet. 2 déjà identifiés.

- **Création de logiciels et des données non brevetables** mais qui constitueront des secrets de fabrication sur le lot 2



- **Communication:**

2 communiqués de presse identifiés

Participation aux grands salons dédiés à la Tech - Vivatech, Forum Teratec, Hello Tomorrow, Quantum Week, Q2B, Quantum Matter

Interventions sur les campus des grandes écoles (ENS, Polytechnique, etc)

C12

Leading the next materials leap in quantum computing

hello@c12qe.com

Advantages of the tech

1. A qubit with a very high quality factor

Long coherence time

Fast coupling

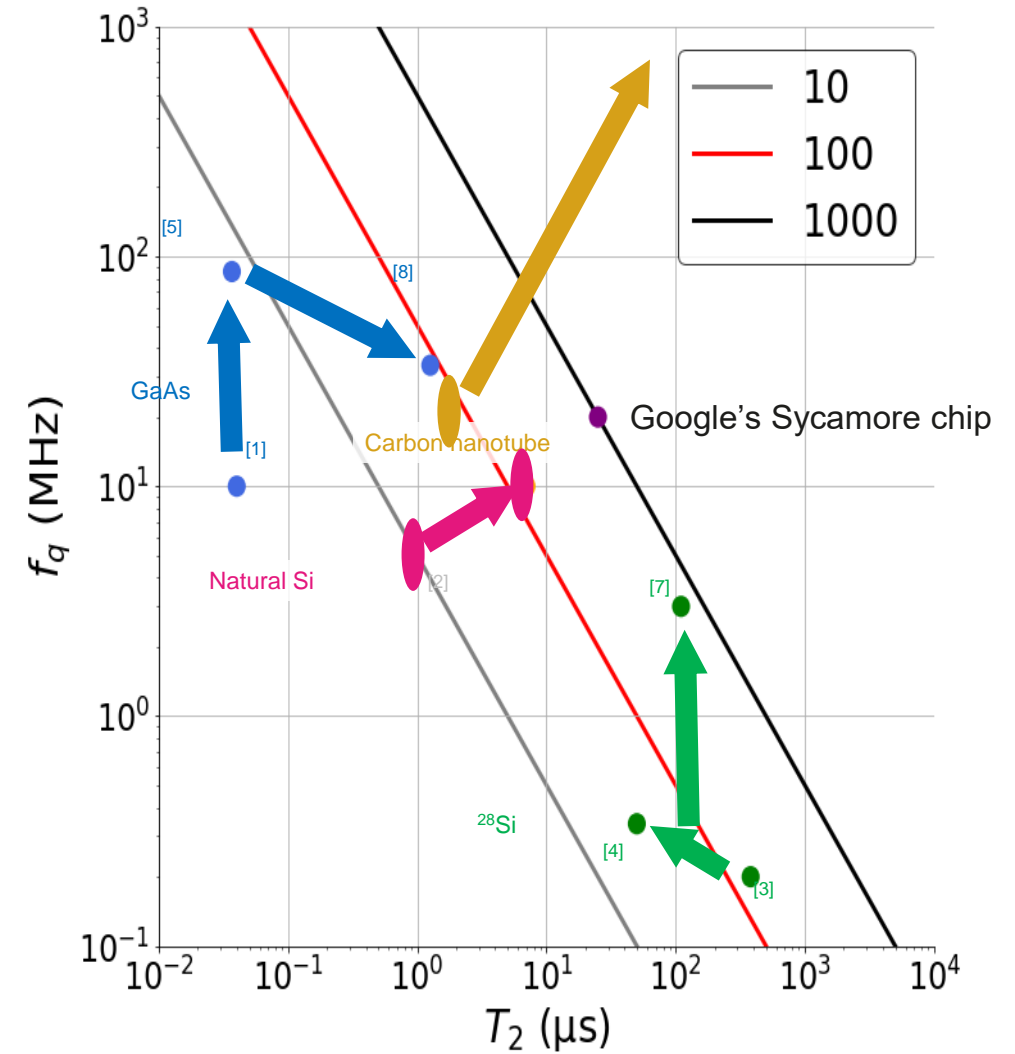

[1] F.H.L. Koppens *et al.*, *Nature* **442**, 766 (2006).

[2] E. Kawakami *et al.*, *Nat. Nanotechnol.* **9**, 666 (2014).

[3] M. Veldhorst *et al.*, *Nat. Nanotechnol.* **9**, 981 (2014).

[4] M. Veldhorst *et al.*, *Nature* **526**, 410 (2015).

[5] J. Yoneda *et al.*, *PRL* **113**, 267601 (2014).

[6] K. Takeda *et al.*, *Sci. Adv.* **2**, e1600694 (2016).

[7] J. Yoneda *et al.*, *Nat. Nanotechnol.* **13**, 102 (2018).

[8] T. Nakajima *et al.*, *Phys. Rev. X* **10**, 011060 (2020)

[9] T. Cubaynes *et al.*, *npj, Quantum Information*, (2019) 5:47

Spin qubit in a ultra-pure material

Less than **0.5** nuclear spin per dot

Vacuum isolation (**oxide-free**)

Control of confined phononic modes

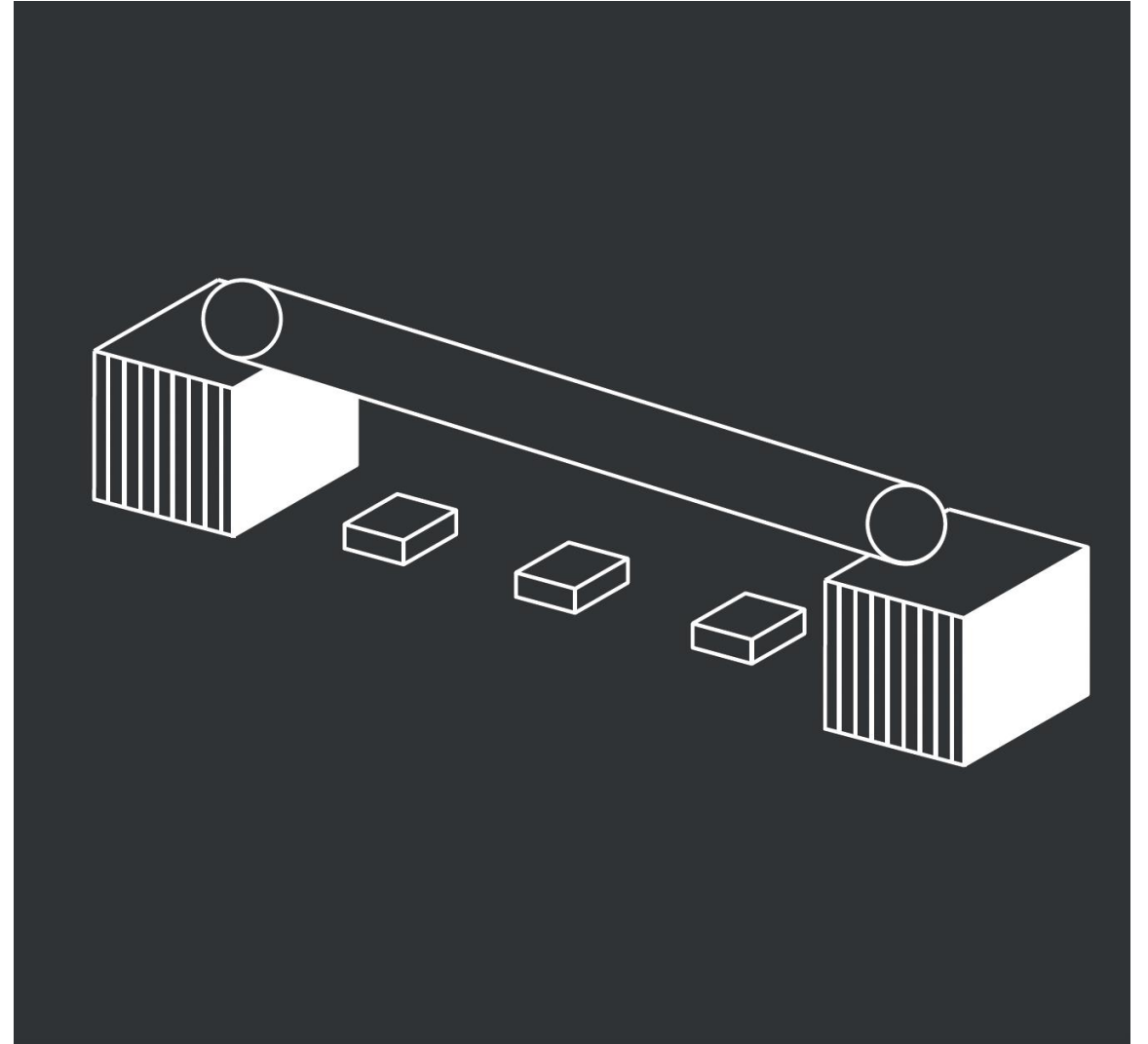

Fast coupling

Microwave on-chip control

2-qubit gate duration – c. 500 ns

1-qubit gate duration – c. 80 ns

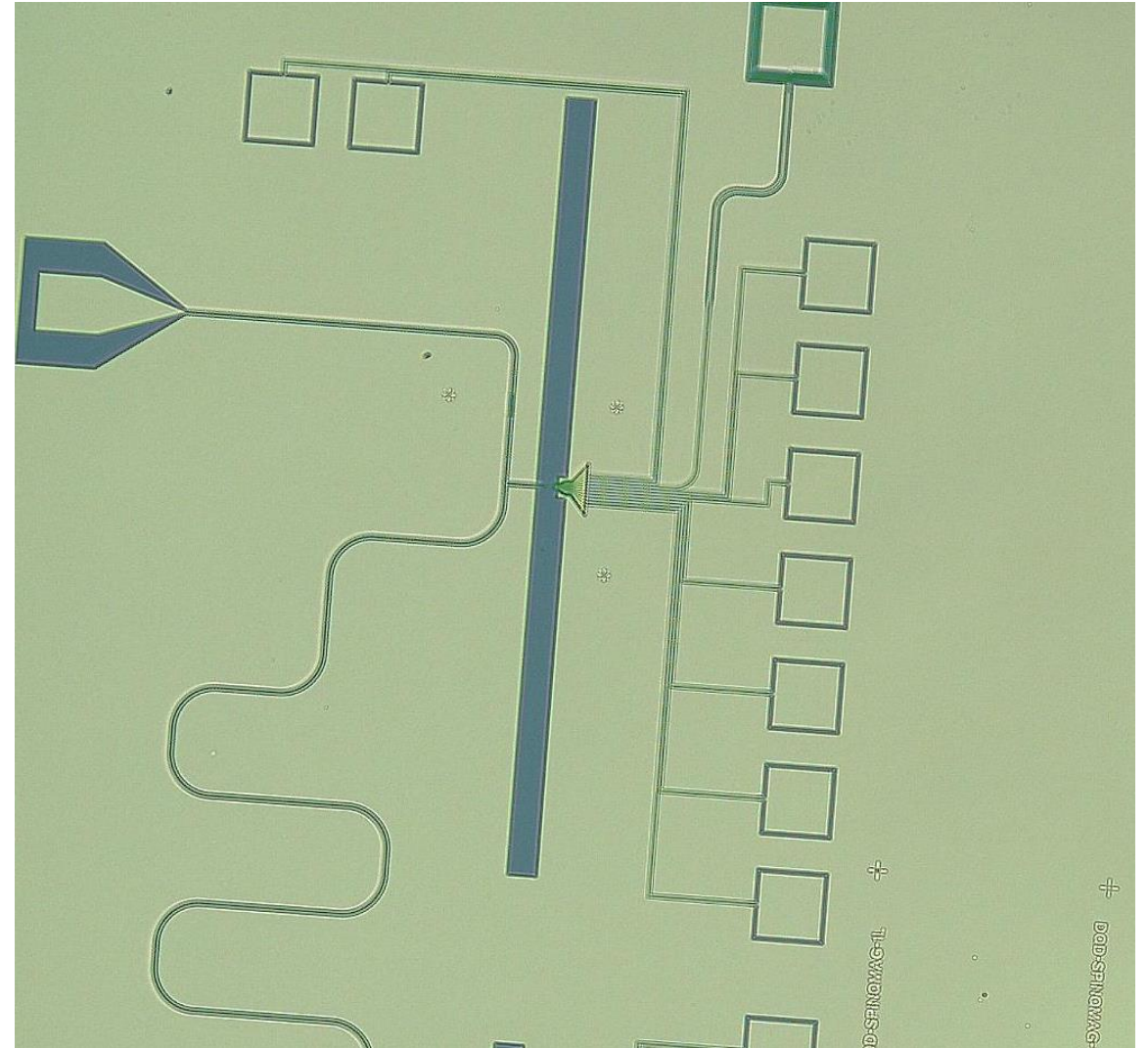

2. A unique solid-state architecture

All-to-all connectivity

Exponentially tunable spin-photon coupling

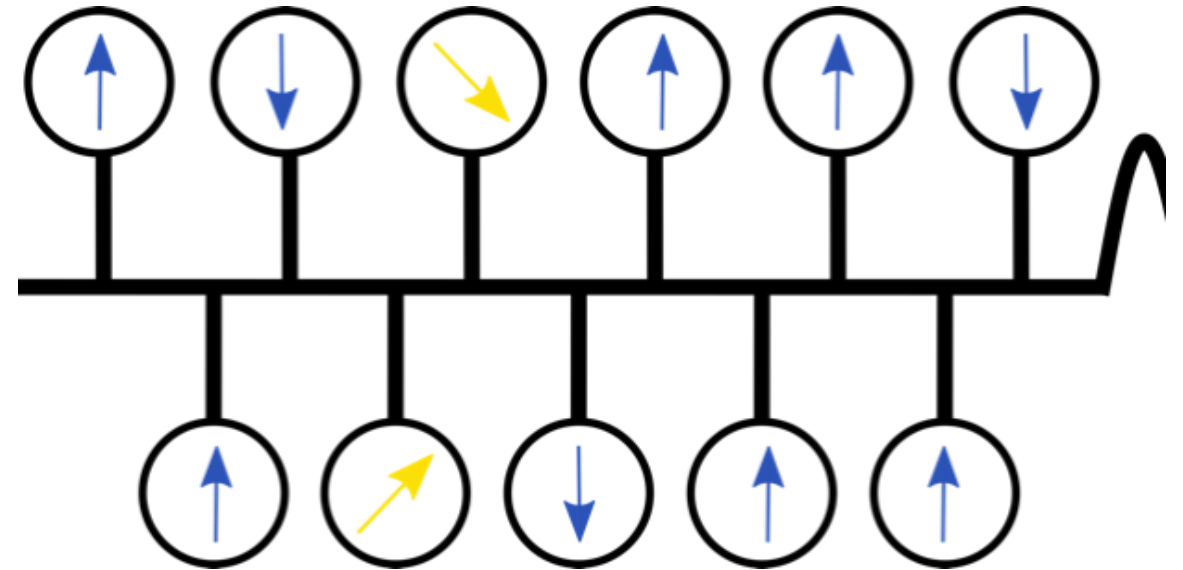

3. Scalable quantum computing

Semiconductor integration & high qubit density

Qubit pre-selection

Quantum error correction

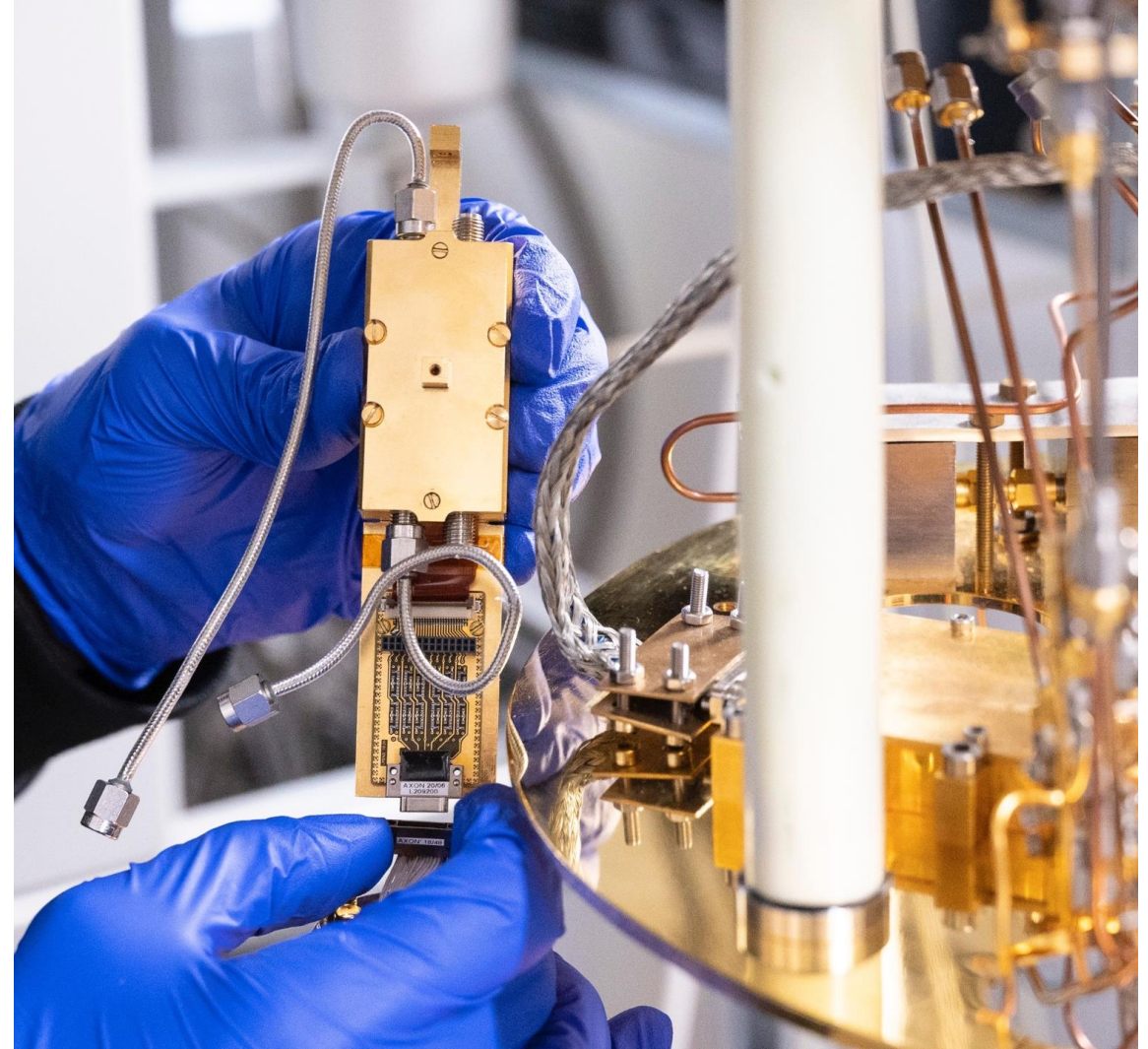

Electrically Gated Semiconductor Qubits

Patented **nano-assembly** process

Small qubit footprint

Use of fabrication methods similar to
classical electronics

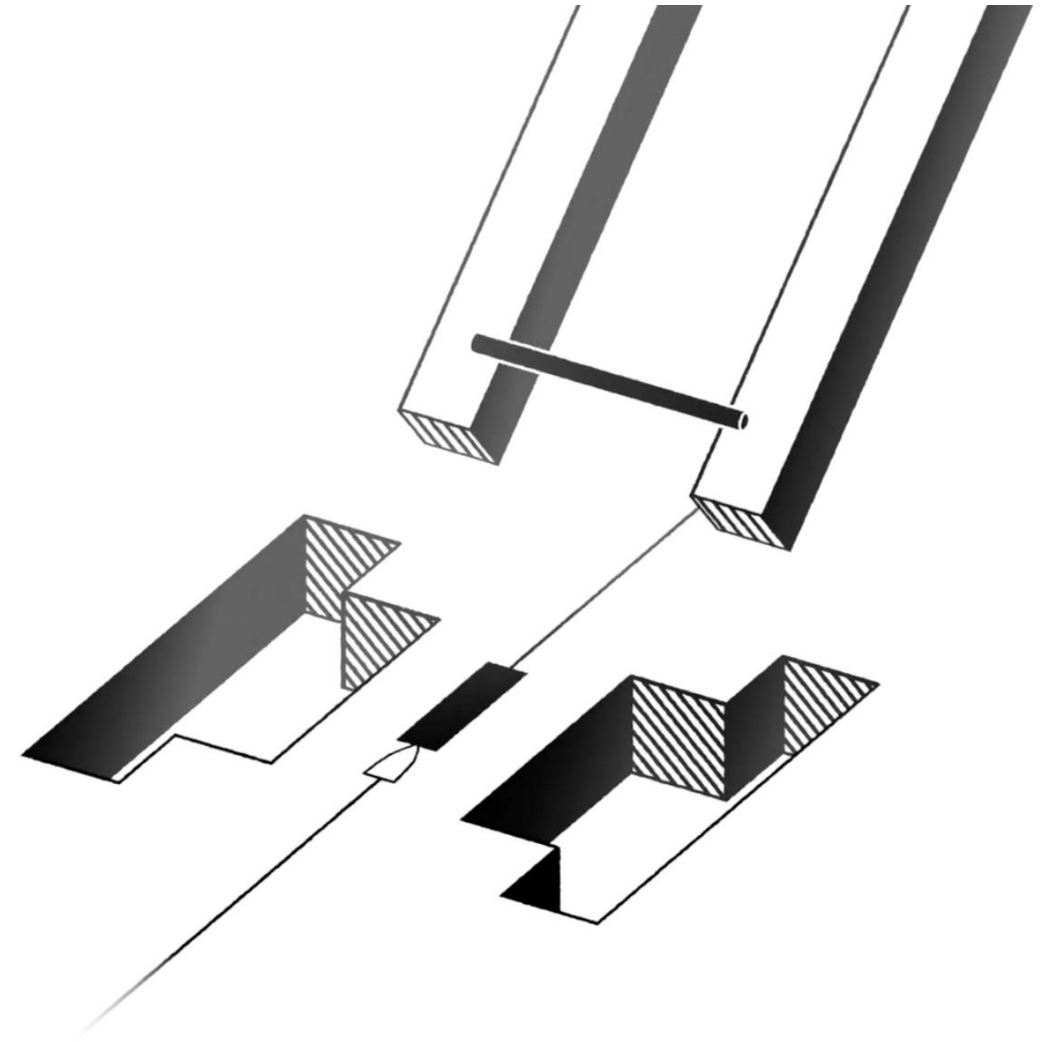

[projet]

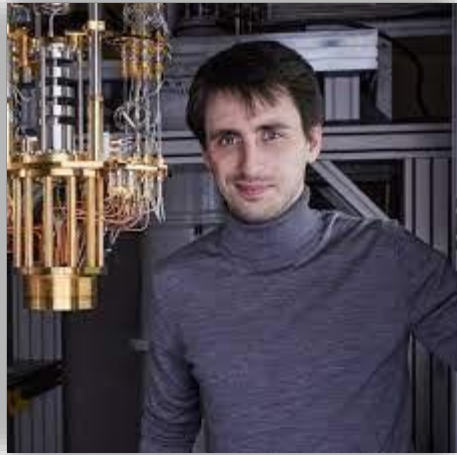

Théau Peronnin
CEO
Alice & Bob



Grégory Golf
Stratégie, Innovation, Business Development
Atem

[QRYOLink]

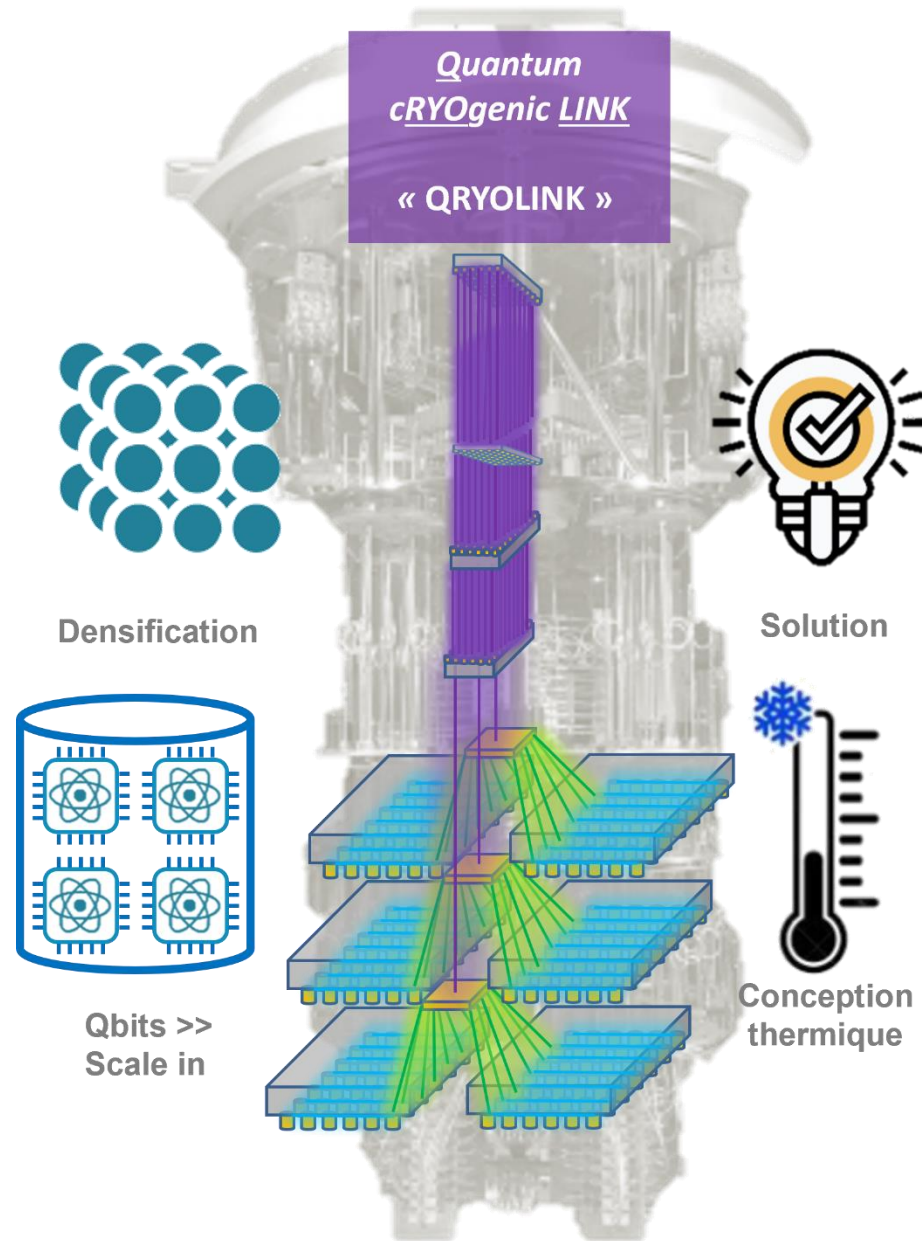

Ne plus faire du système de câblage une technologie limitante pour le passage à l'échelle de l'ordinateur Quantique cryogénique !

- **Souveraineté industrielle**
- **Avancées technologiques**

PARTENAIRES QRYOLINK

Grands groupes/ ETI

- **CryoConcept** (*cryostat*)
- **Radiall** (*connecteurs, composants passifs RF, câblage*)

PME

- **Atem** (*opérateur plateforme, expertise circuits RF, câblage, porteur*)
- **Alice&Bob** (*architecture quantique, puce quantique supraconducteur*)
- **C12** (*architecture quantique, puce quantique spin*)

Labos

- **CNRS - Institut Néel** (*hébergement plateforme, puce quantique CMOS*)
- **CEA Leti** (*nouveaux concepts de routage*)

Budget 7,946M€
Aides (SUB+AR) 6,116M€



ALICE & BOB



I-DÉMO
SOUTIEN AUX PROJETS
STRUCTURANTS DE R&D

OBJECTIFS

Augmenter le nombre de canaux avec une meilleure efficacité économique

- Densification (ultra miniaturisation, nouvelles générations de câbles, canes de câblage, amagnétisme...)

Augmenter les performances de débit par canal

- Multiplexage
- Saut en fréquence
- Guide d'onde plastique

Diminuer les charges thermiques

- Lignes complètes intégrant la transmission du signal et l'atténuation thermique
- Matériau
- Nappes de câblage

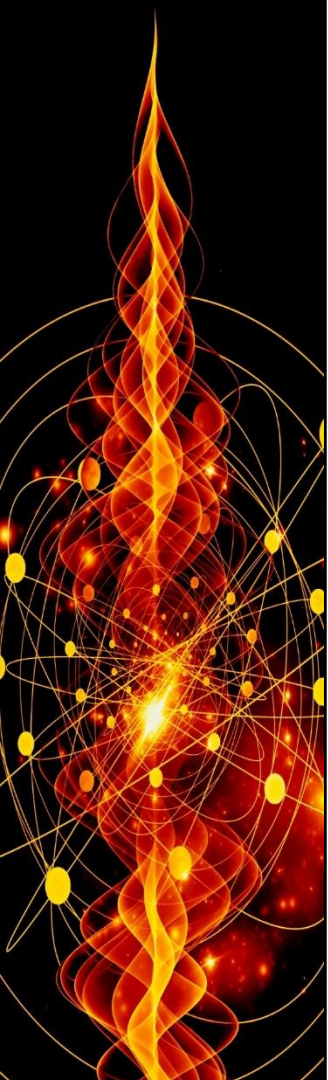

APPROCHE QRYOLINK

Approche expérimentale

- Cryostat avec électronique de pilotage et de contrôle de qubits chez Néel
- Réalisation d'abaques câblage + composants RF actifs/passifs

Approche architecture quantique/simulation

- Simulation architecture quantique : bilan de liaison / bilan thermique
- Couplage avec QEI
- Spécification de la prochaine génération de câblage

Approche industrielle

- Canes de câblage 100 et 1000 qubits NISQ
- Appui industrialisation de la filière
- Nouvelles solutions de câblage

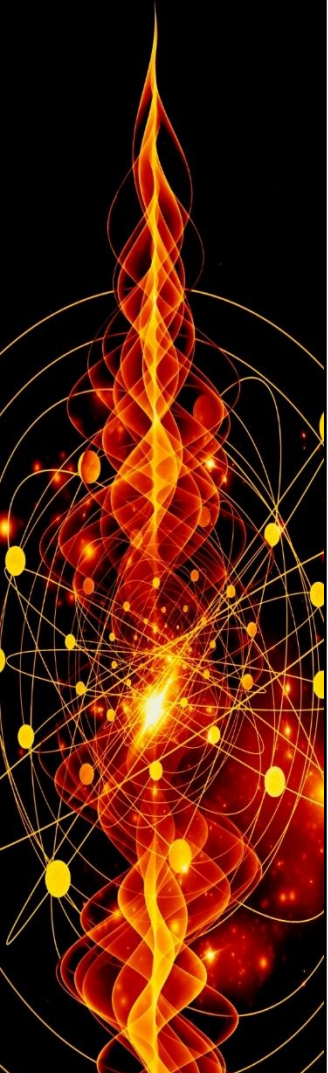

APPORTS SYSTEMATIC

Support à l'organisation des journées plateaux pour monter le projet

Positionnement du projet vers le bon guichet et soutien du guichet auprès de la SNQ

Conseils et revue du projet I-Demo (soutenance blanche)

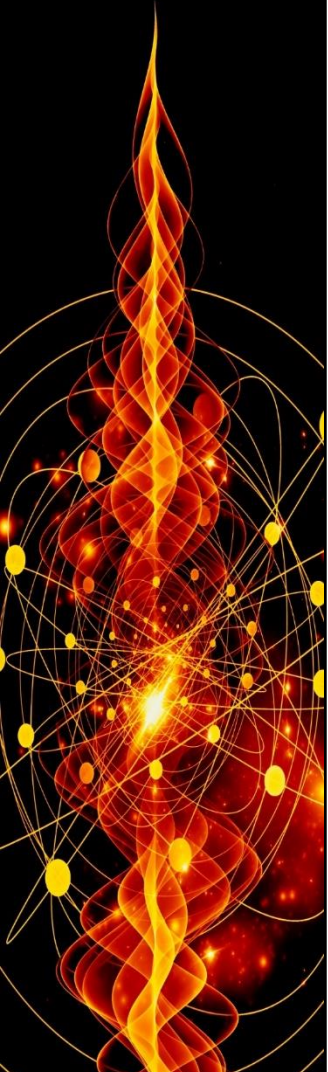

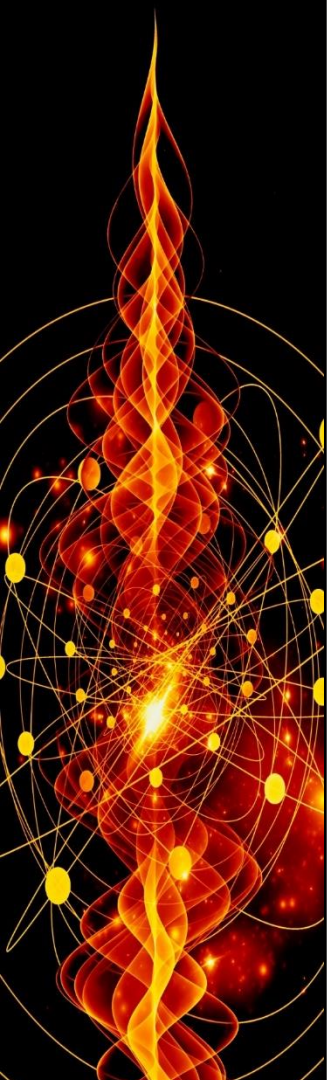

PAUSE ON SE RETROUVE A 11H30

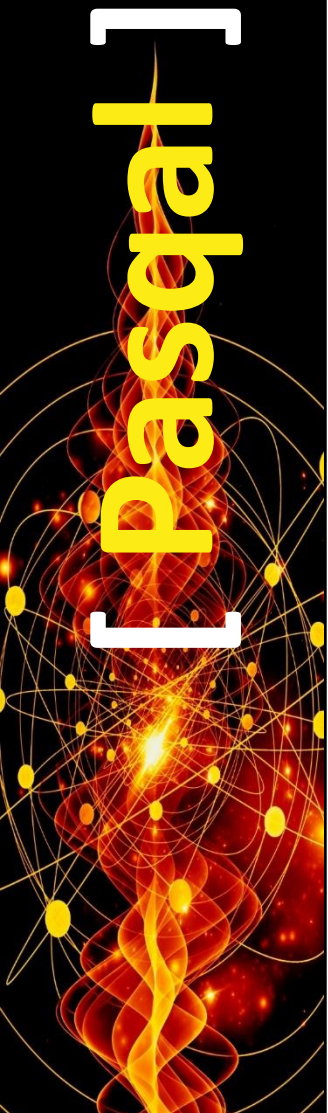

Christophe Legrand
SVP Global Business Development
Pasqal

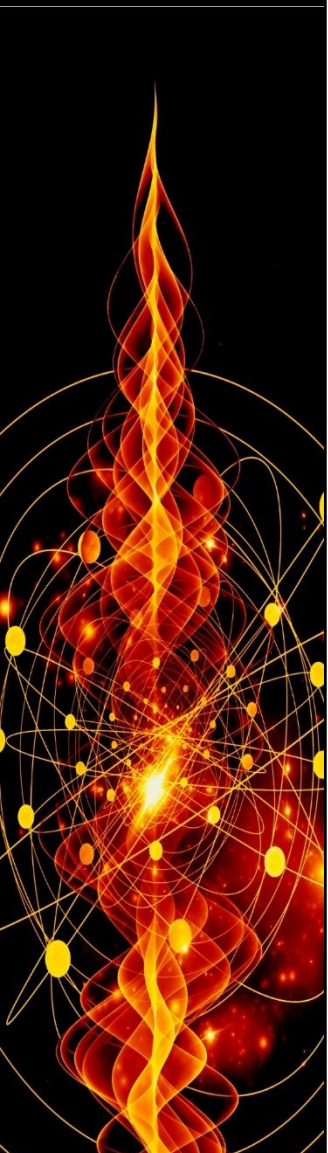

Christophe Legrand
SVP Global Business Development

Louis-Paul HENRY
Head of Applications and Hamiltonian Design

Strictly private and confidential. Not for distribution.

Pasqal at a Glance

20+

CLIENTS

2 QPUs sold via HPCQS framework, activities in 10 countries, and engagements with top cloud distributors

40

YEARS

History in quantum technologies

350+

QUBITS

Best-in-class qubit count and path to 10,000 qubits available in the cloud in 2026

100+

EMPLOYEES

18 nationalities
Based in 6 countries

18+

PATENTS & APPLICATIONS

800+ publications

FULL-STACK

QUANTUM HARDWARE AND SOFTWARE TODAY

Practical Quantum Advantage in 2024

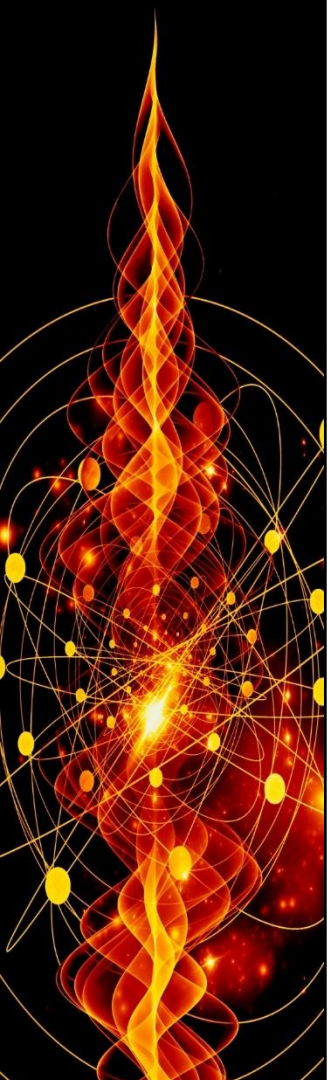
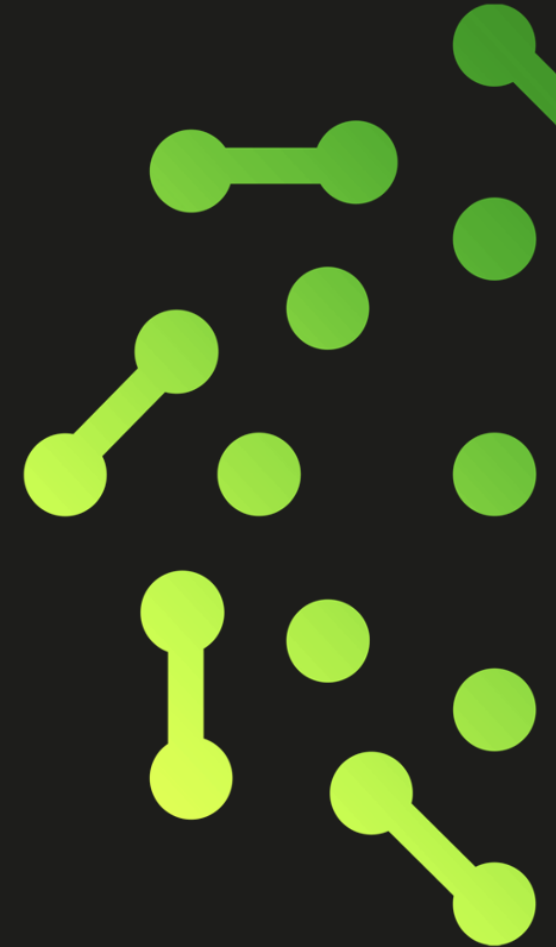

Global Challenges Raise Opportunities for Quantum Computing



1

ENERGY



2

ENVIRONMENT



3

MOBILITY

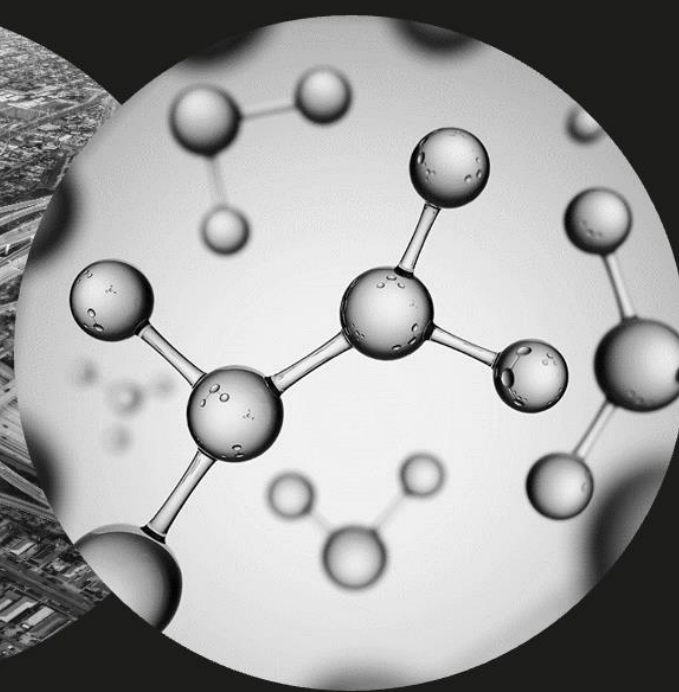

4

HEALTH

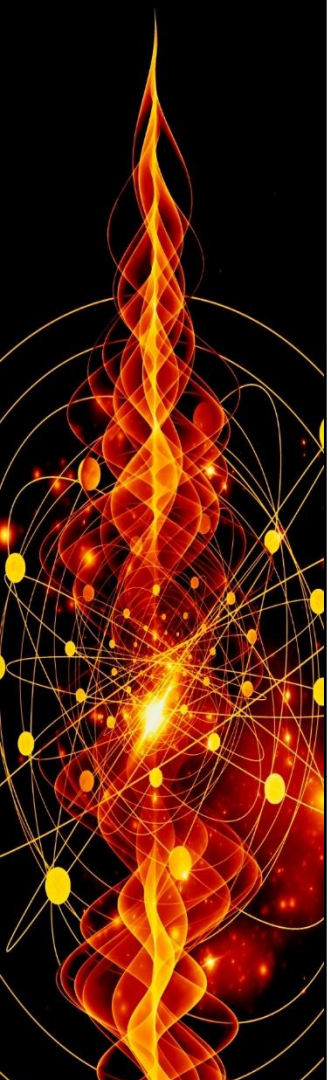

Our Full-Stack Solution is Key to Driving Customer Success

Pasqal's comprehensive full-stack offer covers the full range of needs from the quantum computer hardware to the way to use it on personalized software on use cases

Hardware¹

Gen 1
100 / 200-Q

Gen 2
512 / 1,024-Q

Gen 3
5,000 / 10,000-Q
and beyond

GPU Cluster
Emulator

Offerings

Access



- Cloud access
- Data center install
- On-premise install

Platform



- Coding platform
- GUI
- Software integrations

Solutions



- Turnkey solutions per problem and sector
- Chemistry, CFD², Finance

Libraries



- Quantum (ready) algorithms per mathematical problem
- PDE, optimization, ML

Support



- R&D support
- Tech support
- Maintenance

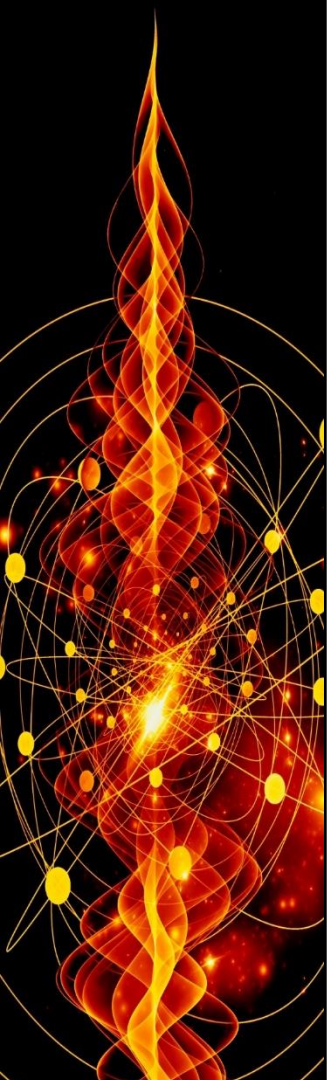

Best-in-Class Ecosystem



Partnership	Commentary	Partners / Customers
End-User Pool (Public & Private)	The end-user pool is comprised of academic research groups and industrial companies both developing direct partnerships with <u>Pasqal</u> for scientific discovery and commercial applications	
Cloud Access & Remote HPC	Pasqal's QPUs will be in public HPC centers offering remote access, and accessible via major commercial cloud platforms as well as its own cloud	
Development of Application Portfolio & Software Stack	Quantum application providers are using Pasqal's processors to serve their customers' needs	
Programming Environment (QC Framework and Open-Source Library)	<u>Pasqal's</u> QPUs can be programmed using major languages and frameworks	

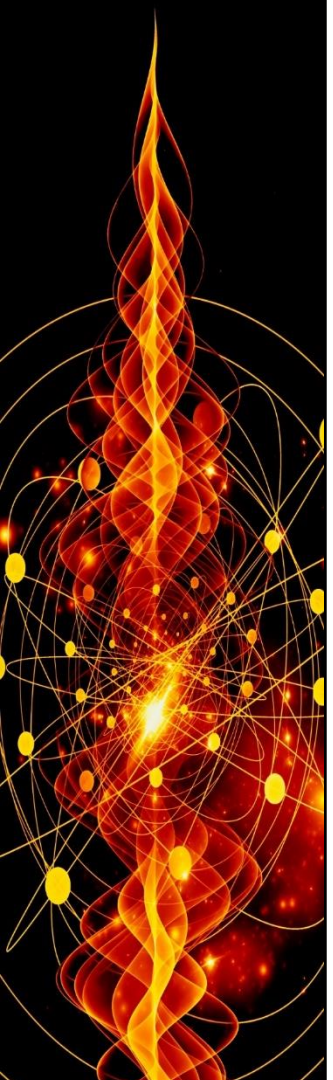

Plug and Play Quantum Computers for Customers



Quantum computers compatible
with **standard environment**



Setup at **room temperature**



Industrial **off-the-shelf** components



Low energy consumption
(equivalent to 4 hair dryers)

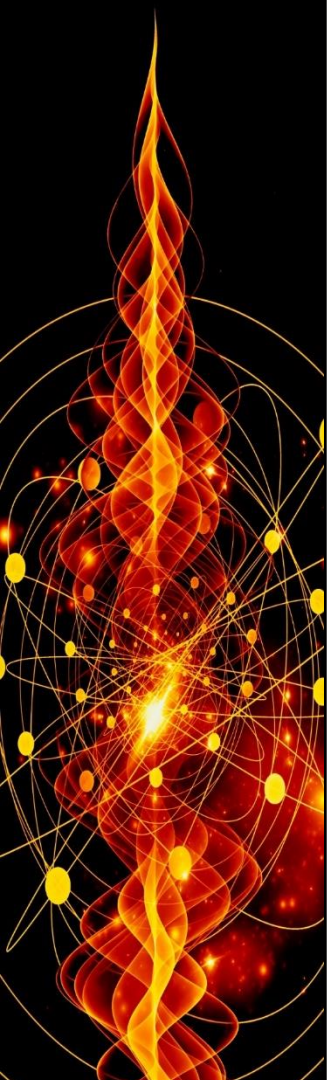



Our Core Software Methods are Driving To Quantum Advantage





Pasqal's current two core proprietary methods (QEK¹ and DQC² / QQM²) are prime candidates for near-term industry relevant Quantum Advantage

 Denotes patent protected



Graph ML^[1]

-  Jan-22 experiment with 30 qubits showed that we can already implement a feature-rich quantum kernel that can not be classically simulated
-  **Practical Quantum Advantage expected with 100-200 qubits within the next 1-2 years**
-  R&D to identify use-cases where, at these sizes, QEK can significantly outperform all classical state-of-art solvers



PDE / SDE^[2]

-  Digital-analog approach is the best direction to reach **Practical Quantum Advantage**
-  DQC needs very few shots and repetitions to train and low gate / pulse fidelity requirements
-  **Practical Quantum Advantage expected with 100-200 qubits within the next 3-4 years**
-  R&D to identify use-cases which promise early Quantum Advantage and on parameterizing / testing the algorithm for these use-cases

Chemistry / Physics^[3]

-  Physics / Quantum-materials: 2021 Pasqal proved **Quantum Advantage** for 196 qubits^[4]; focus should be on finding relevant (non-academic) use-cases (**Quantum Advantage**), perhaps in the area of quantum/superconducting materials
-  Molecular chemistry: many shots and repetitions required, therefore unlikely to see Quantum Advantage below 3,000 qubits making runtimes prohibitive
-  Graph ML and PDE / SDE are also powerful tools to solve Chemistry / Physics problems

Optimization^[5]

-  QAOA^[6] can be implemented in neutral atoms without digital gates but only by using embedding techniques to map the problem graph to the physical qubit graph
-  Given the need for embedding, there could be a chance of mid-term Quantum Advantage
-  Graph ML and PDE / SDE are also powerful tools to solve optimization problems



AQUARE

2021-2023

Smart-charging of
electric vehicles

FIND MIS



AQUAPS

2021-2023

Optimisation of
resource allocation

MINIMIZE QUBO



AQUAEDP

2022-2024

Aerodynamic
design

SOLVE PDE





SMART-CHARGING OF ELECTRIC VEHICLES

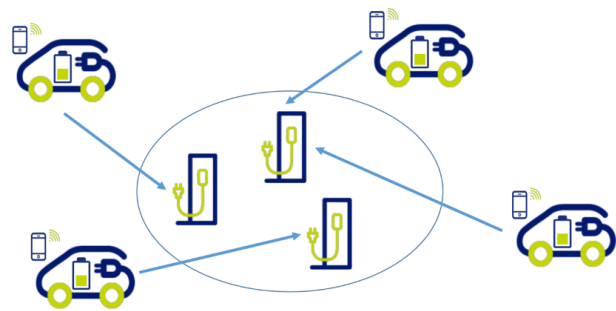
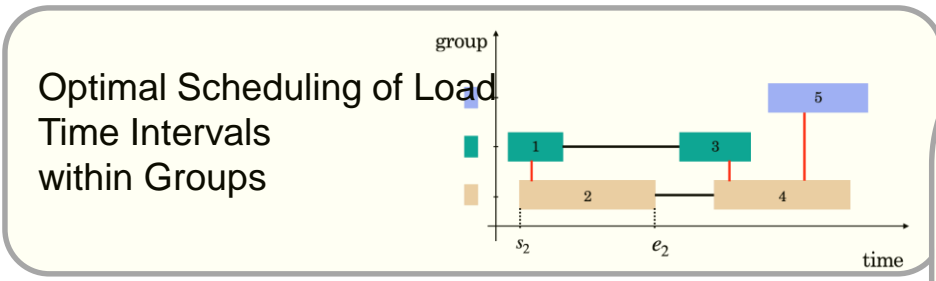

The problem can be mapped onto a **Maximum Independent set (MIS)** problem.

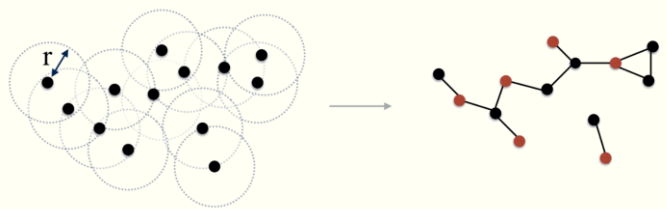

This is an example of application for which a quantum advantage is reached with 1,000 qubits¹.

¹ M. F. Serret *et al.* PRA **102**, 052617 (2020)

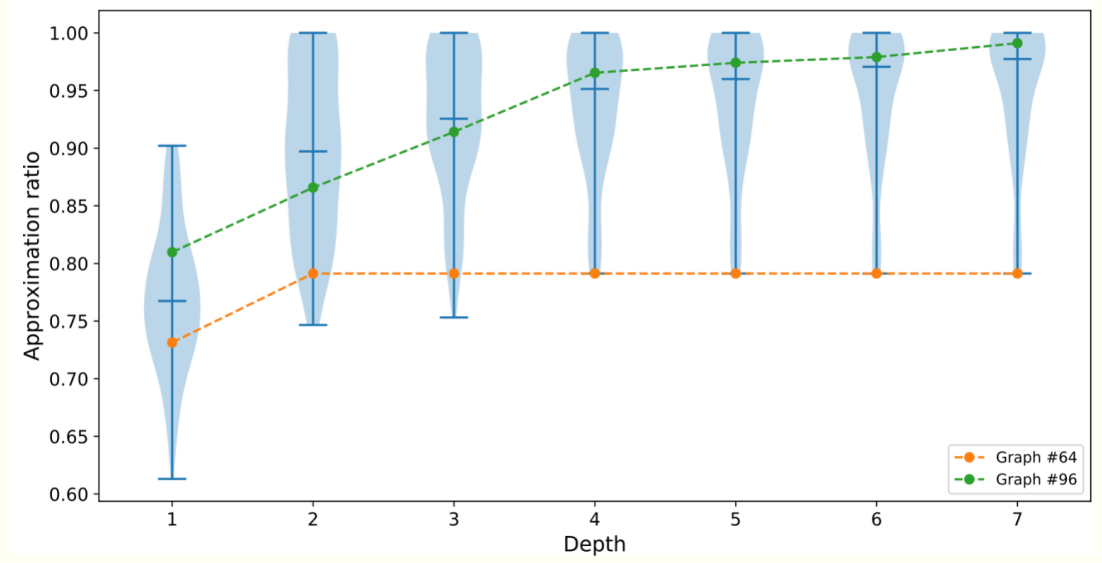

A quick convergence towards large approximation ratios. The emulation was performed for 84 instances (real data provided by EDF) and 15 qubits.



C. Dalyac *et al.* EPJ Quantum Technology **8**, 12 (2021)



Implementation on Pasqal's QPU



OPTIMISATION OF RESOURCE ALLOCATION

Planning & scheduling
Can be written as PDDL,
CNF, or directly in QUBO

CNF

$$C = C_1 \wedge C_2 \wedge \dots \wedge C_p$$

$$C_a = b_{a,1} \vee b_{a,2} \vee \dots \vee b_{a,k_a}$$

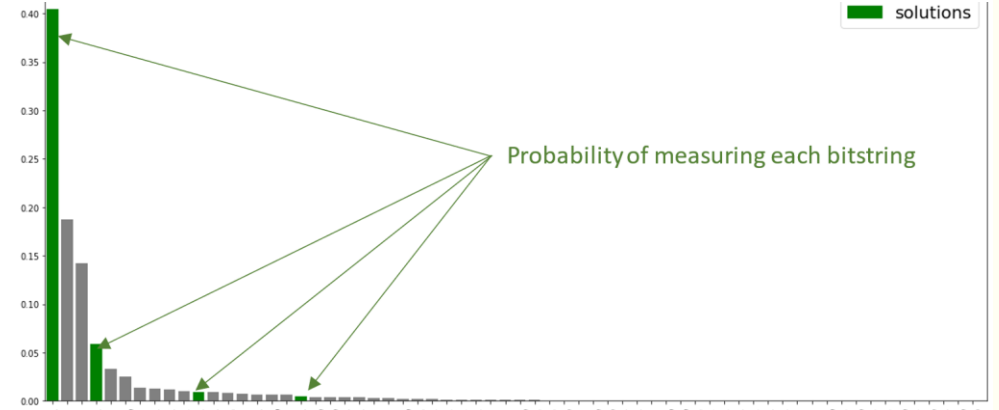
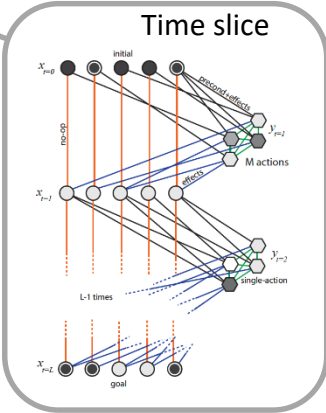
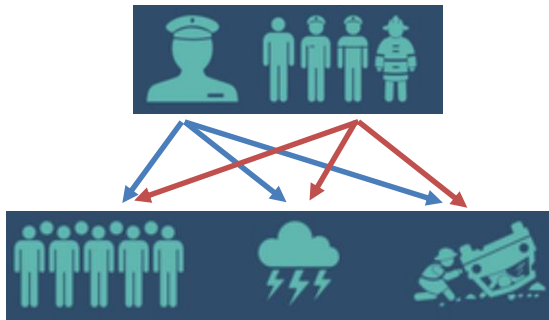

Solutions are found with reasonable success for most cases.



The problem can be mapped onto a **Quadratic Unconstrained Binary Optimisation (QUBO)** problem :

$$\operatorname{argmin}_{\{b_i\} \in \{0,1\}^N} \sum_{i,j} Q_{ij} b_i b_j = ?$$

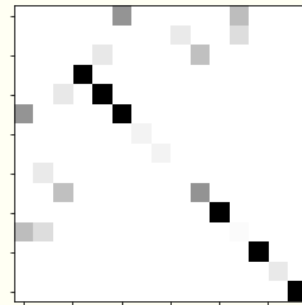

Closely related to the energy of the atoms in a QPU

Q1-Q2 2023

Pursue refinement of the problem

Q3 2023

Implementation on Pasqal's QPU



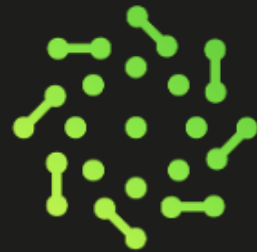
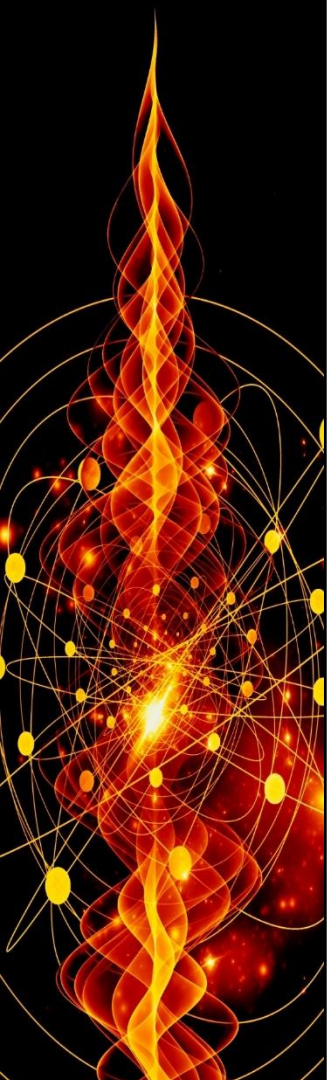

PASQAL

Thank You

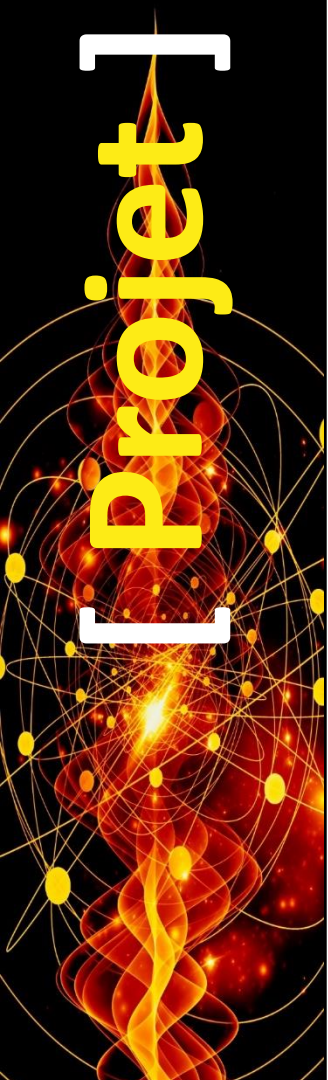

Jean Senellart
Chief Product Officer
Quandela

Des sources de photons
uniques...

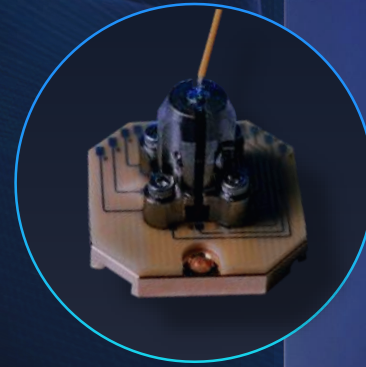

...au premier ordinateur
photonique NISQ sur le
cloud

Jean Senellart, CPO
Projets Quantiques - Systematic
Palaiseau (FR) – December 2022









60 people dedicated to Quantum Computing & Quantum Photonics

QUANDELA



>40 PhDs and engineers in algorithms, semiconductors, optical technologies and computer science

Offices, laboratories, clean-room facilities in

-  Paris, Massy, Palaiseau
-  Munich
-  Barcelona
-  Rome



Commercialization activity driven by the needs of the scientific community

Since 2018 we commercialize reliable

- single photon source devices
- opto-electronics modules to enable the emerging of q-technologies

Clients

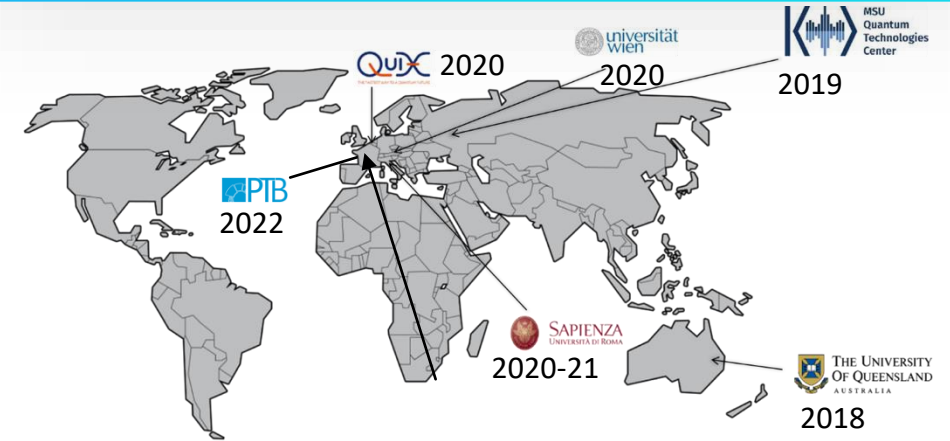

Our references





Hardware architecture

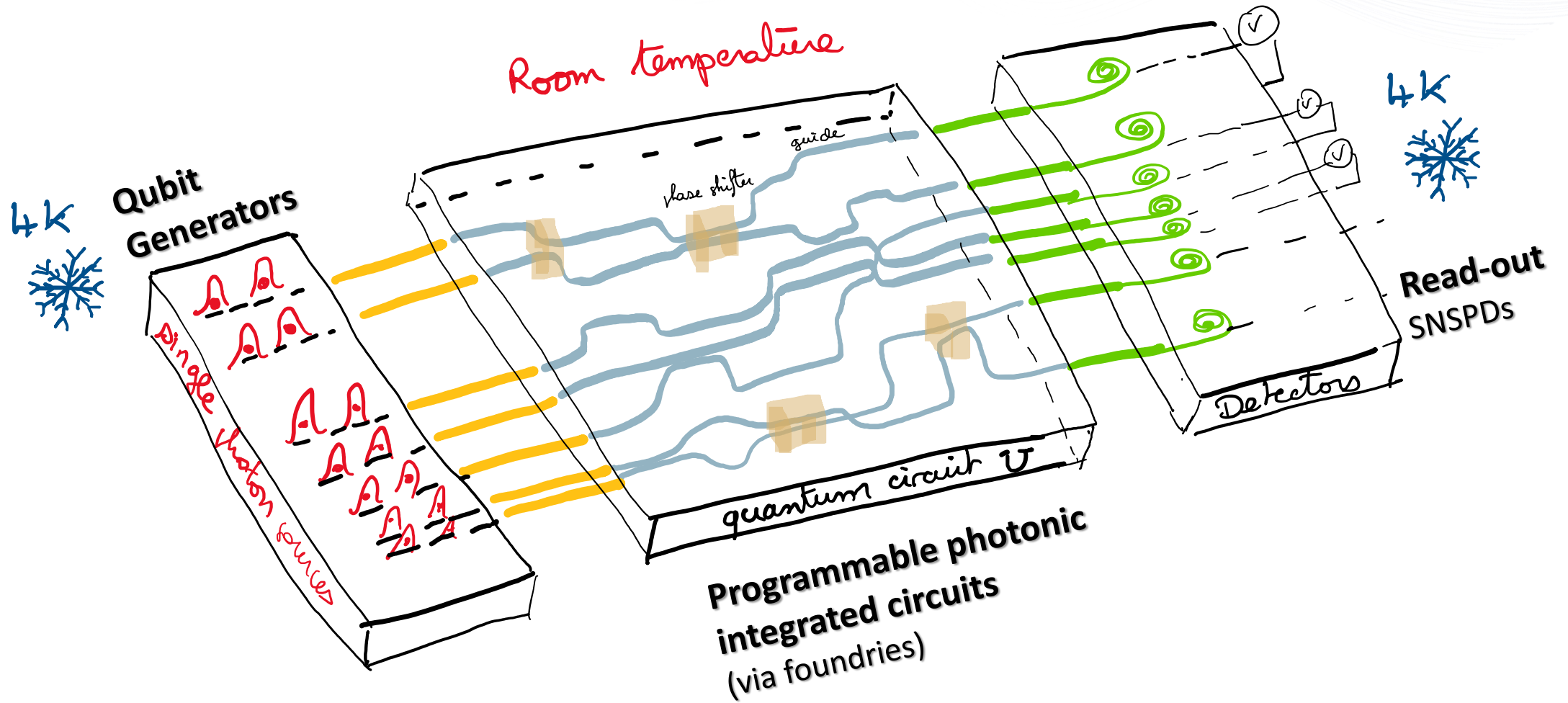

*Feedforward not shown



Unique approach based on the efficient generation of Quantum Light

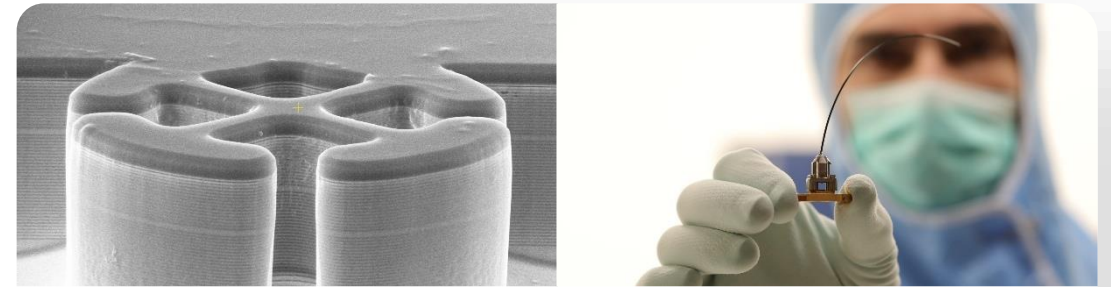
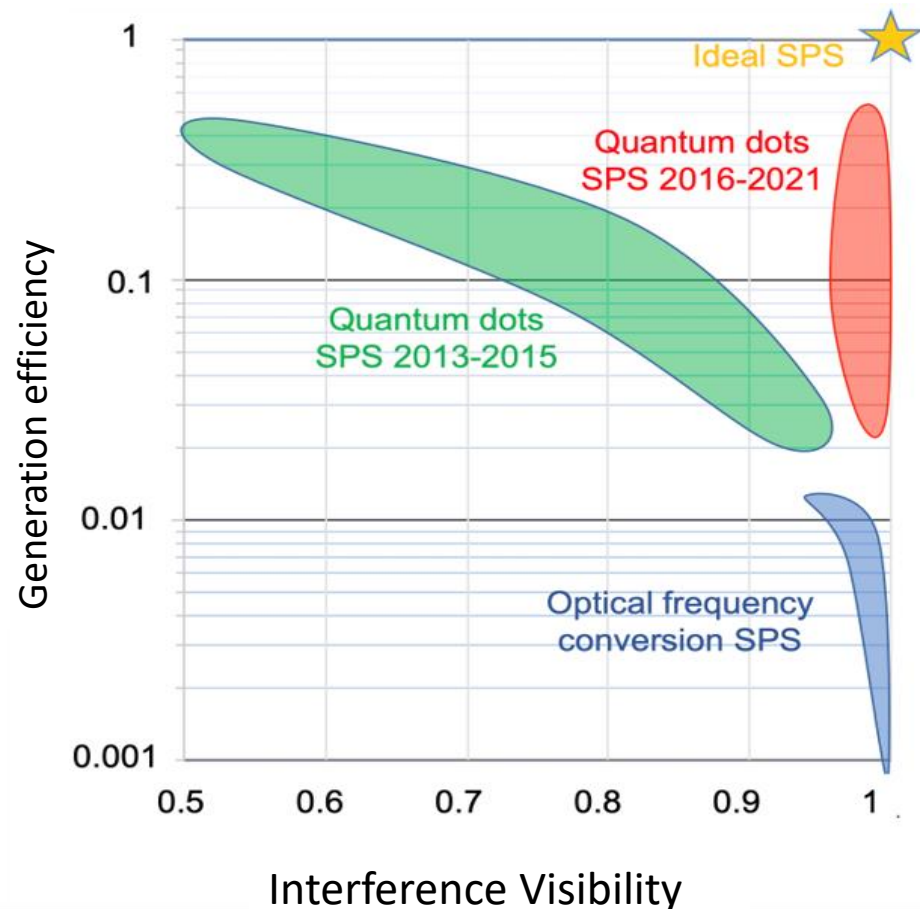

First worldwide efficient emission of single photons was a challenge until 2015 with a unique technology of semiconductors (1)

Based on 25 years research at



(1) Somaschi et al. published in Nature Photonics (2016)



We build the first full-stack optical QC



Upgradability offered by modularity

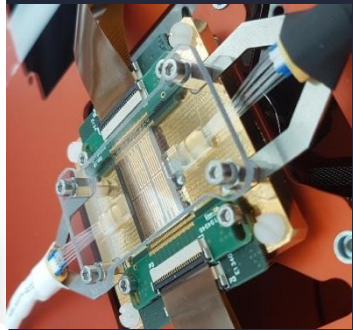

Scalability by the use of optical fibers and semi-conductors (1)

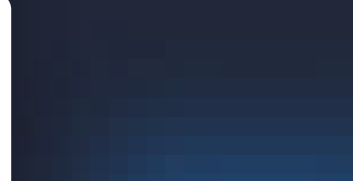

Low energy consumption with optimised and integrated cryostats and compatibility with any environment

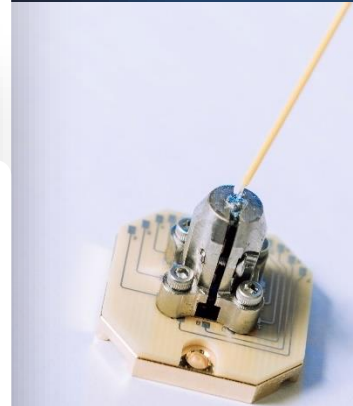

MOSAIQ

End-users

Cloud access or on-premise

Front end

Python Libs, REST API, Visual/Graphical interface, Integration with existing platforms

Compiler

Logical Qubits
<> Photon encoding

Assembler

Calibration, Machine Language

Hardware Modules

Electronics, FPGA, Voltage Sequence

Semiconductors

(sources, photonics integrated chips, detectors,...)

Perceval Optical QC Simulator

(< 20 qubits)

- 1. Main computer
- 2. Lasers & Electronics
- 3. Photonic Integrated on Chip (PIC)
- 4. Qbit-controller module
- 5. Photonic Qubit Demultiplexer (DMX)
- 6. Cryogenically cooled qubit generator



Quandela's Industrial Use Cases



Cybersecurity

- Using **quantum certified randomness** to generate **spy-proof hash keys**
- Developing **next generation post-quantum cryptography** algorithms
- **Applications:** defense and security, banking industry



Molecular Design



- Using **Variational Quantum Eigensolver (VQE)** to resolve **3D-molecular molecule configuration**
- **Application:** drug design in pharmaceuticals



Logistics



- Using **state superposition** to simultaneously explore a large number of paths to research solutions for **NP-hard problems**
- **Application:** drone cohort flight planning



Time-Series Forecasting



- Using **quantum forward propagation** to detect **weak signals** in long time series
- **Application:** finance industry, insurance industry

Generation of optical linear cluster states

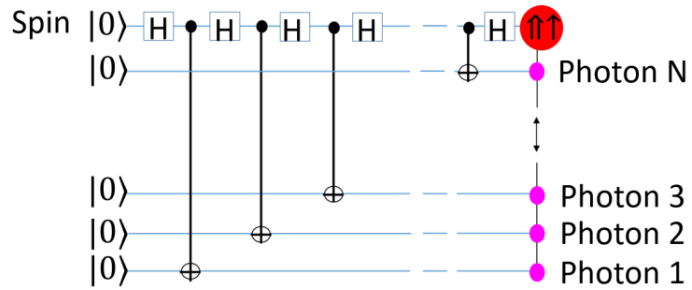

Linder, Rudolph, PRL, 103, 113602 (2009)

Emission of indistinguishable and entangled photons with a high brightness

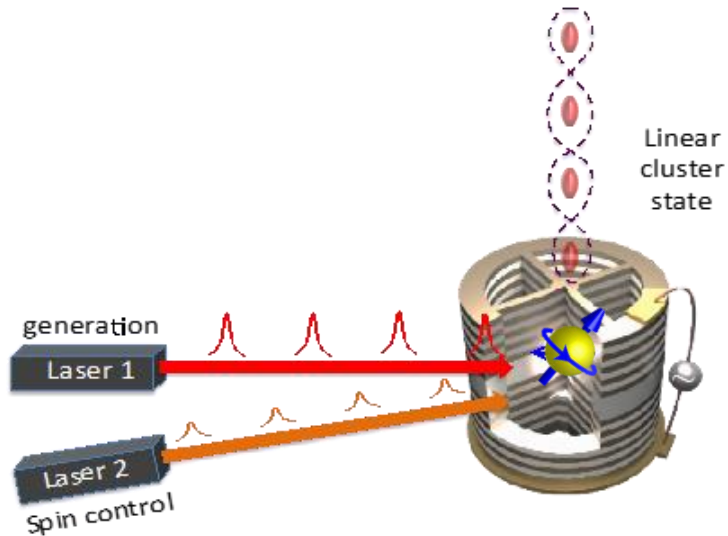

Small mT magnetic field + compact cryostat

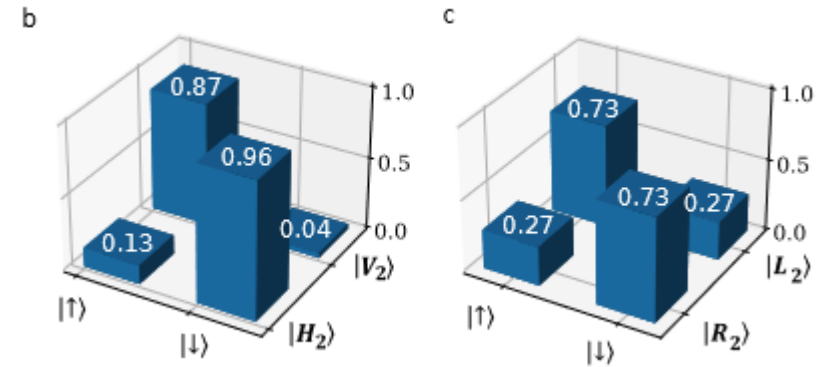
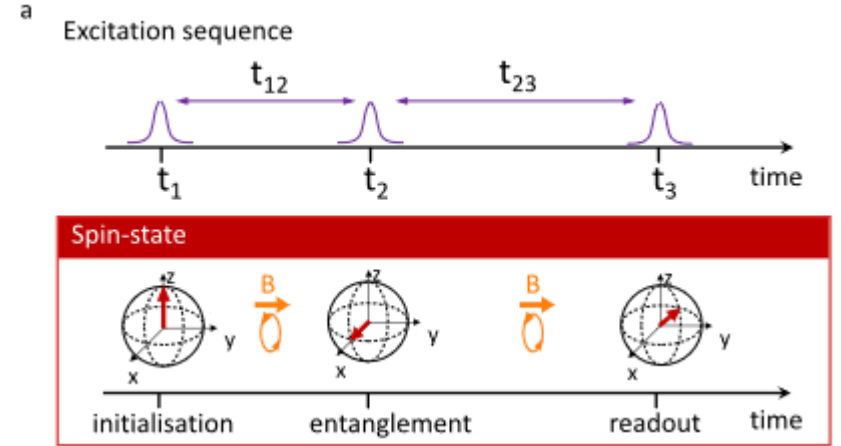

Coste et al.

High-rate entanglement between a semiconductor spin and indistinguishable photons

<https://arxiv.org/abs/2207.09881>



In a Nutshell, Quandela exploits the best of qubits

1 Matter Qubits: Ions, Superconductors, Cold Atoms...

2 Static qubits: physically located in a QPU (fixed)

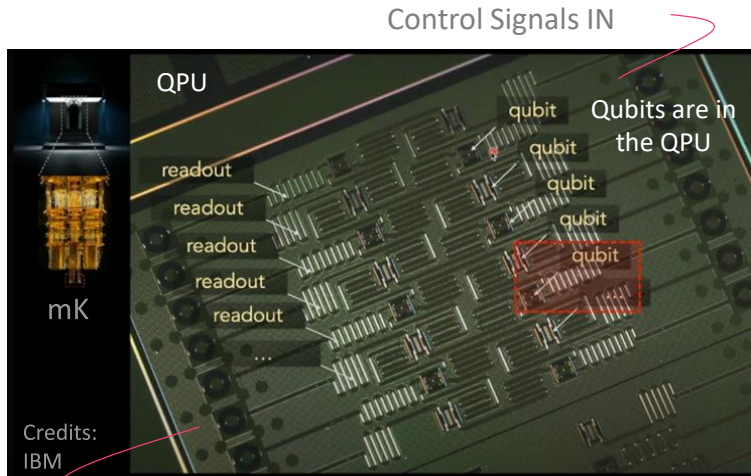

Read-OUT Signals

Qubit# \leftrightarrow physical size - Manufacturability roadblocks

Each qubit undergoes DECOHERENCE \rightarrow errors with #qubits

Highly EFFICIENT 2-qubit GATES

3 Photonic Qubits

Photons are Flying Qubits \rightarrow moving through the QPU and through optical fibers

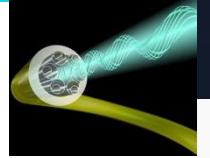

4 1 PHOTON IN 2 SPATIAL MODES (DUAL RAIL ENCODING)

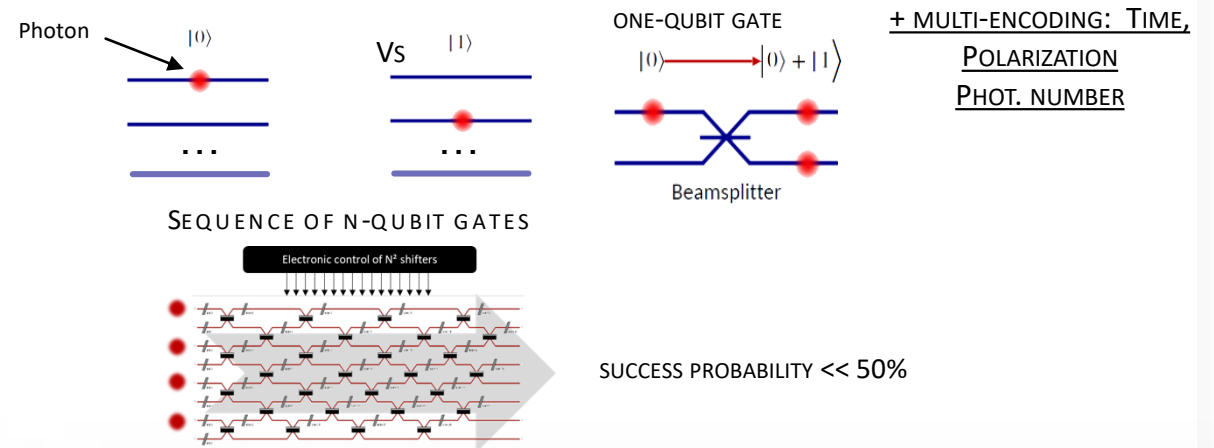

Increase Qubit# with "FIX" hardware size

ROBUST qubits (room temperature) + MANIPULATION with standard optics

2-qubit GATES are NOT EFFICIENT (probabilistic) \rightarrow HARD to scale

Quandela exploits the efficient manipulation of optical qubits but tackle probabilistic nature of gates with a matter-based qubit generator

00:00:00



Quandela: the first European QPU provider in the cloud

Open to all

Jobs Status

sample_count	90%	Completed	23/10/2022 10:11:09	gqucloud	Simulator Jean 2
sample_count	90%	Completed	23/10/2022 10:10:53	gqucloud	Simulator Jean 2
sample_count	90%	Completed	23/10/2022 10:10:47	gqucloud	Simulator Jean 2
sample_count	90%	Completed	23/10/2022 08:56:23	gqucloud	Simulator Jean 2
sample_count	90%	Completed	23/10/2022 08:56:08	gqucloud	Simulator Jean 2

Platform Status

Simulator	See detail →
Simulator Status	maintenance
Total pending jobs	0
Description	Perfect chip simulator

News

Achernar is live

Achernar is live on Quandela cloud preview! Check it out...

ACHERNAR

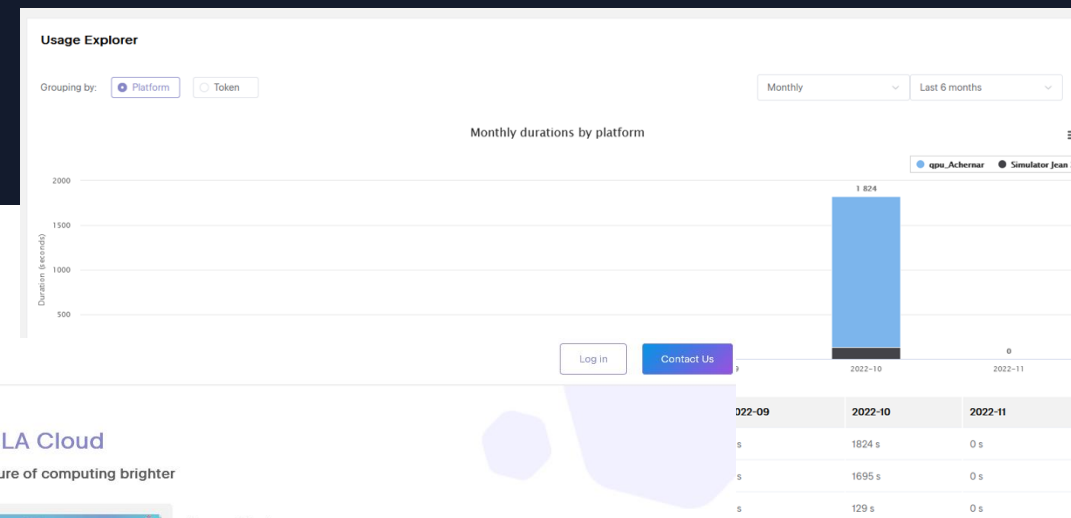

QUANDELA Cloud

Making the future of computing brighter

Usage Explorer

Track your team activity, time spent on different platforms, remaining credits, and estimate costs

Quandela's cloud-based platform gives you access to photonic quantum computing, enabling you to develop and deploy algorithms that optimise solutions.

[Get Started for Free](#)

- Simulator – Clifford Generic
Noiseless Clifford sampler for up to 20 photons
[Available](#)
- Simulator – SLOS Generic
High performance noiseless Strong Linear Optic Simulator for up to 10 photons
[Available](#)
- QPU – Achernar
2-photon, 4-mode, specialized Bell State preparation quantum processor unit
[In Maintenance](#)
- Simulator – Ache
Noise simulator for Ache
[Available](#)

Test one of our three QPUs available in the cloud for free
<https://cloud.quandela.com>

Q Sources de Lumière Quantique (SLQT) - 2020

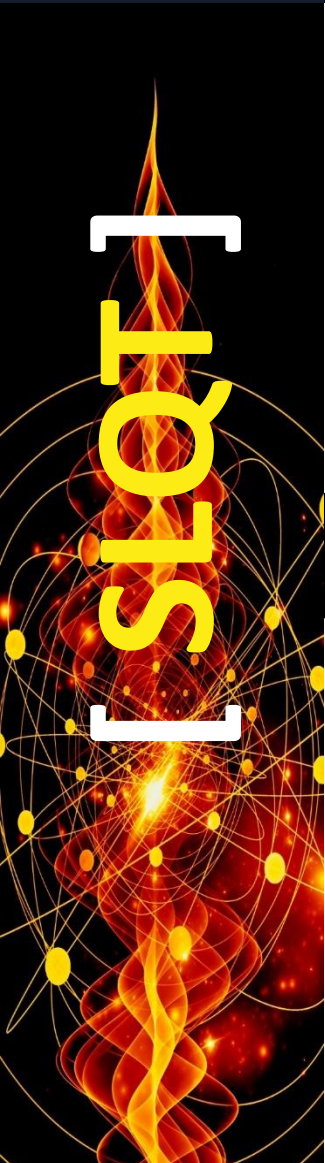

Internet quantique

Sources de photons uniques

Réseaux quantiques actuels

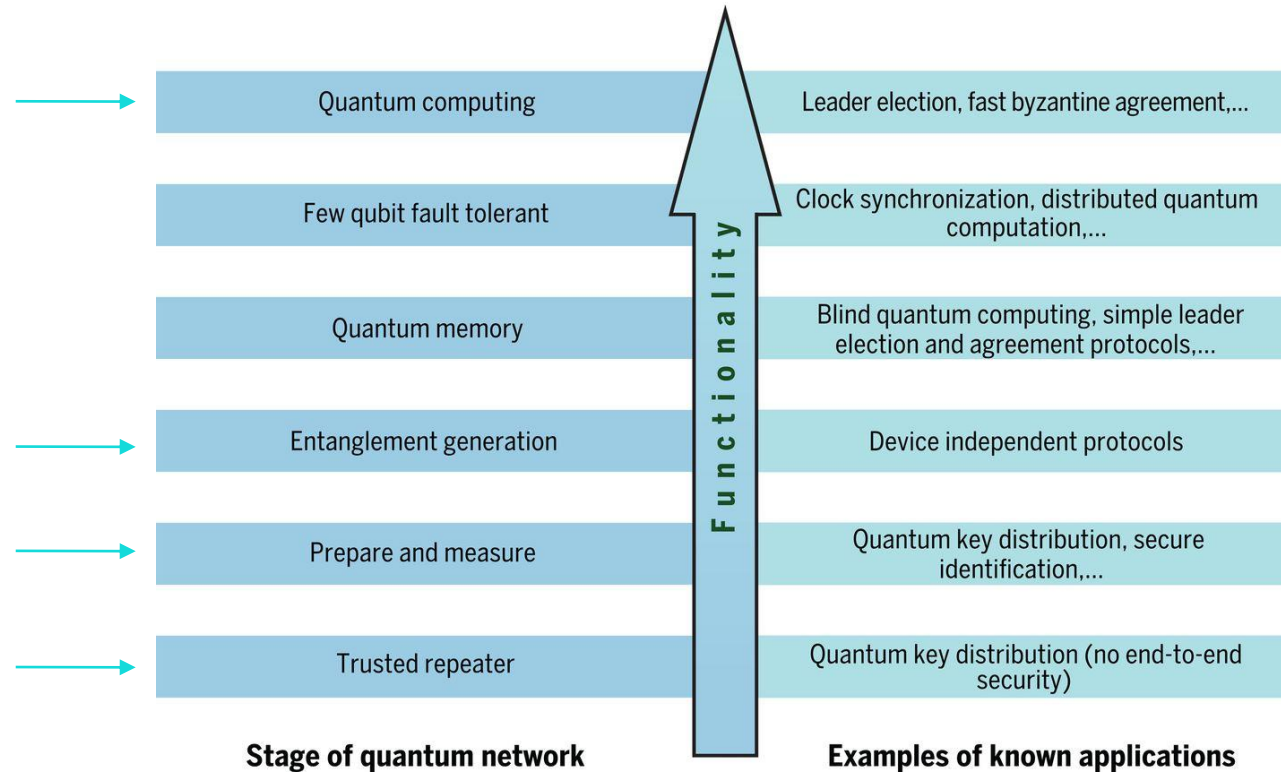

Sécurité cryptographique renforcée

Source: *Quantum internet: A vision for the road ahead*, S. WEHNER, D. ELKOUSS, R. HANSON - SCIENCE 19 OCT 2018

Sources de Lumière Quantique (SLQT) - 2020

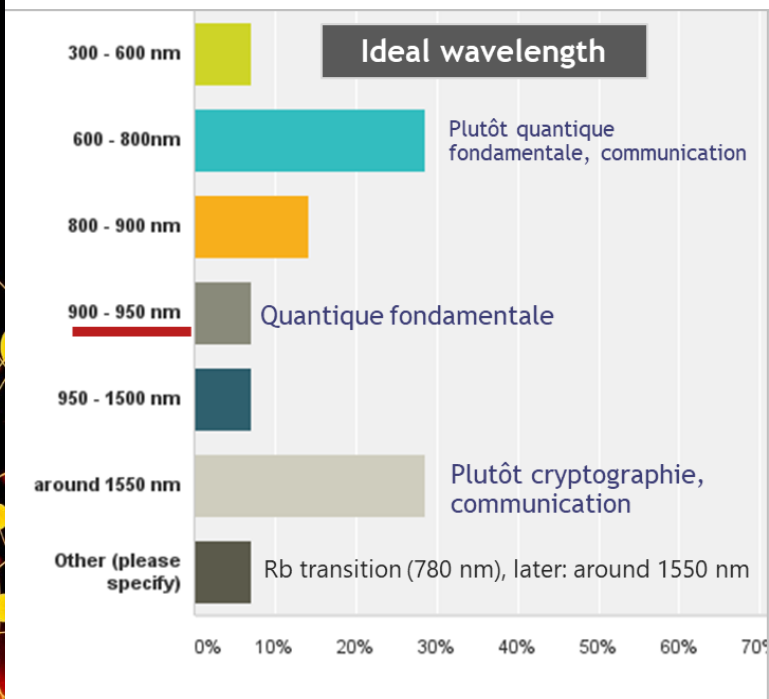
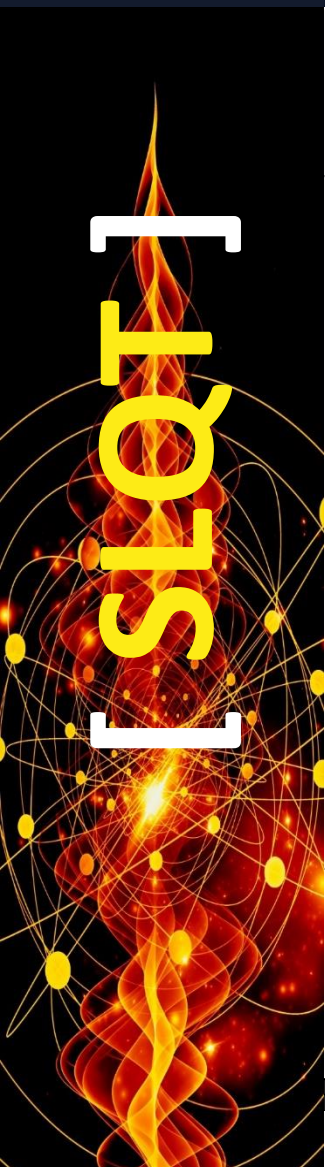

Our devices emit light at 900-950nm now. This wavelength range represents < 10% of the applications in quantum information technologies.

By developing devices at 1550nm, we want to enter the market of quantum communication and quantum computing (for silicon chip compatibility).

Résultat d'un sondage réalisé par Tematys en 2016



Sources de Lumière Quantique (SLQT) - 2020

1 an

Sept. 21

Développement de wafers contenant des émetteurs aux longueur d'onde telecom sans cavité pour l'extraction de la lumière

R&D en collaboration avec



à Palaiseau



Budget de 140k€ pour la collaboration/sous-traitance



10 mois

Développement de la technique pour intégrer les émetteurs dans des cavités optiques et mesure de la brillance

Travail d'ingénierie réalisé dans nos locaux et au sein de la salle blanche du C2N (location)

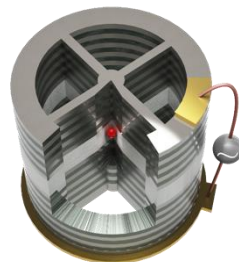
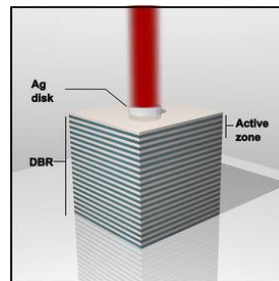

1 an

Juillet 23

Alignement avec des fibres optiques et integration dans des systems compacts industriels

Achat d'un cryostat dédié au programme (40k€)

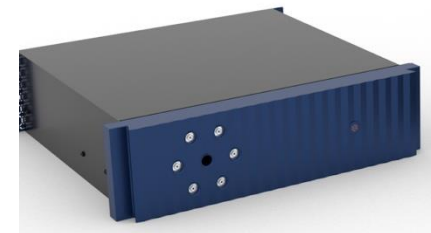
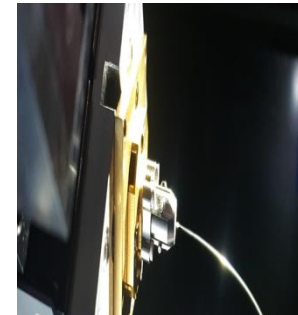



Telecom Single Photon Source For Quantum Key Distribution

Quandela is developing an efficient turnkey telecom single photon source system for QKD applications



15U server rack system

Control Software

Wavelength conversion module

Single photon source control

780 nm Pigtailed Single Photon Source inside a 40K cryostat

>50% conversion efficiency
>100 Signal to noise ratio

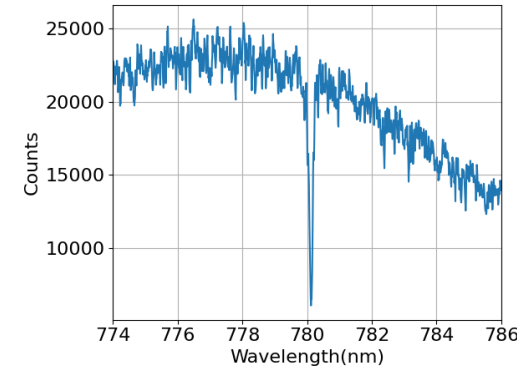
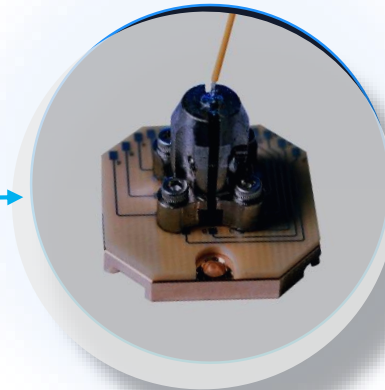
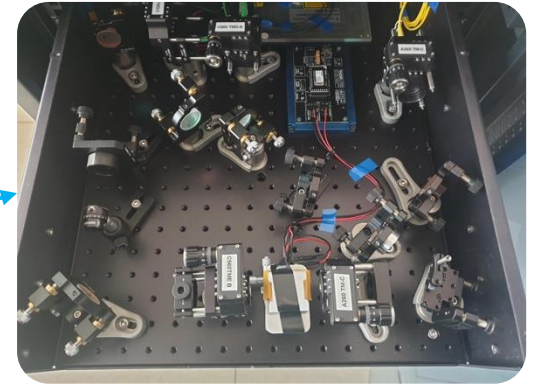

On-going development of high quality factor micropillars at 780 nm

QUANDELA

ROQC
Reconfigurable Optical Quantum
Computer

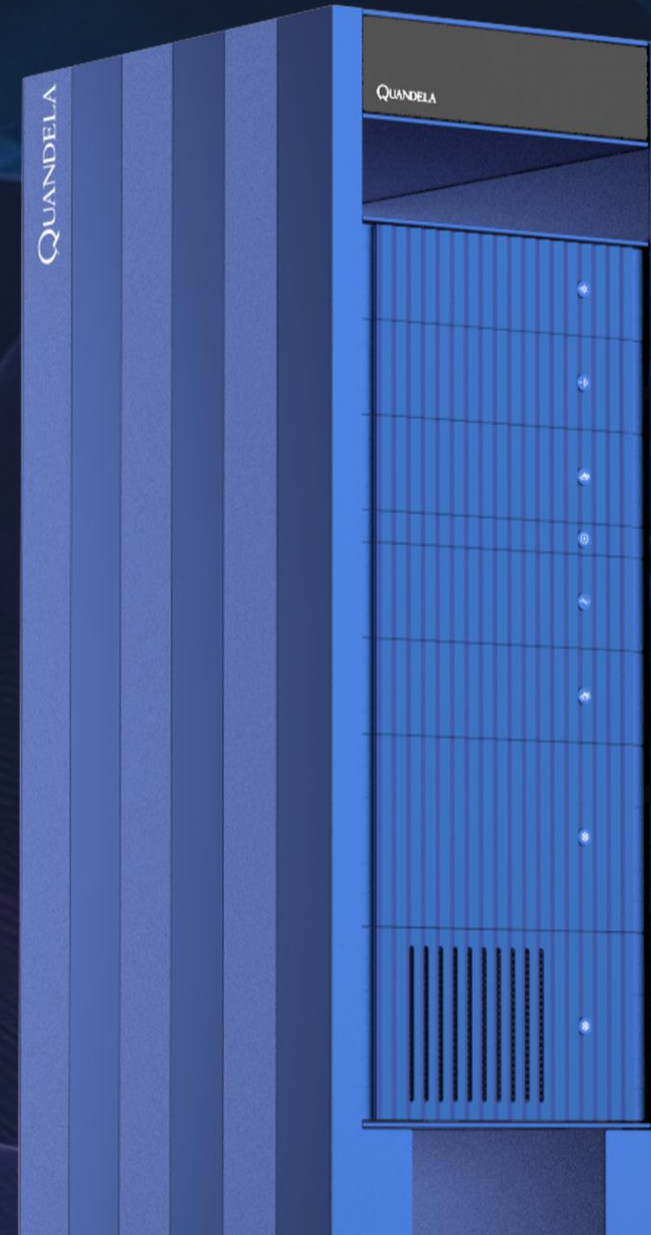



Objectifs commerciaux du projet ROQC (issu du dossier de candidature)

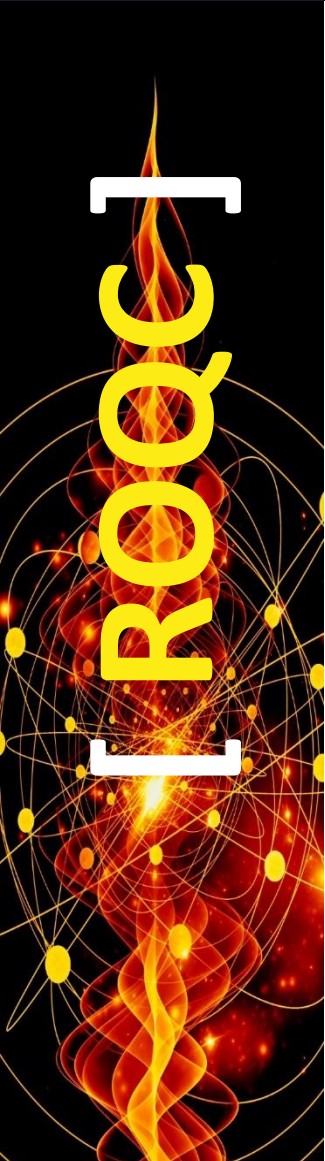

A l'issue du projet ROQC, nous prévoyons de mettre sur le marché (avec une priorité pour le marché européen) **deux produits et une offre de service** :

- Livraison et installation d'un plateforme de calcul quantique chez le client industriel avec une offre de maintenance et de mises à niveau
 - A partir de 1,5-2 M€ HT
- Vente de temps d'accès à la plateforme de calculs via le cloud. L'offre reste à être définie plus précisément. Pendant la phase de tests, un accès limité sera proposé gratuitement pour alimenter le pipe commercial.
- Analyse et étude de problèmes soumis par des client. L'équipe de Quandela spécialisée en théorie quantique, machine learning et algorithmes sera déployée sur des prestations de service afin de former les industriels et réfléchir avec eux à leurs problématiques.

Le projet ROQC vise à développer une plateforme de calcul quantique en utilisant des technologies optiques. Cette plateforme permettra à l'industrie française de commencer à s'approprier d'un ordinateur quantique pour implémenter des logiciels et des algorithmes en langage quantique ainsi qu'à résoudre des problèmes d'optimisation. Grâce à la reconfigurabilité de la plateforme, elle pourra aussi être utilisée comme un vrai générateur quantique de nombres aléatoires pour des applications de cryptographie.

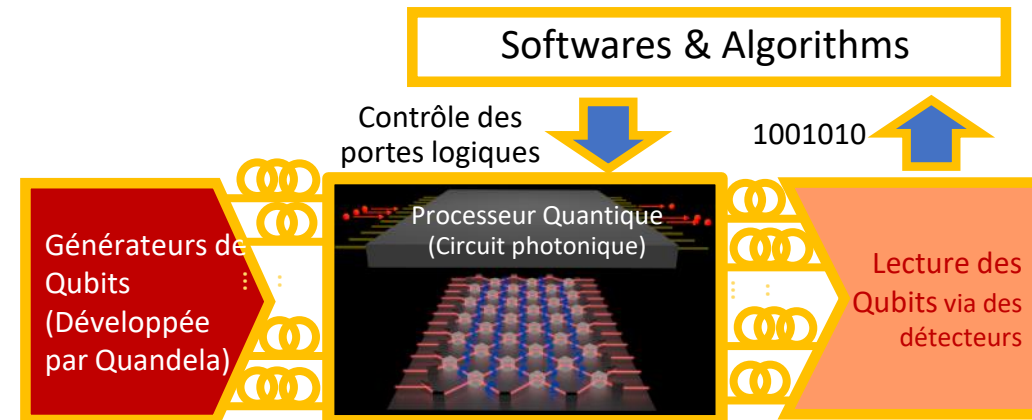



Plan initial

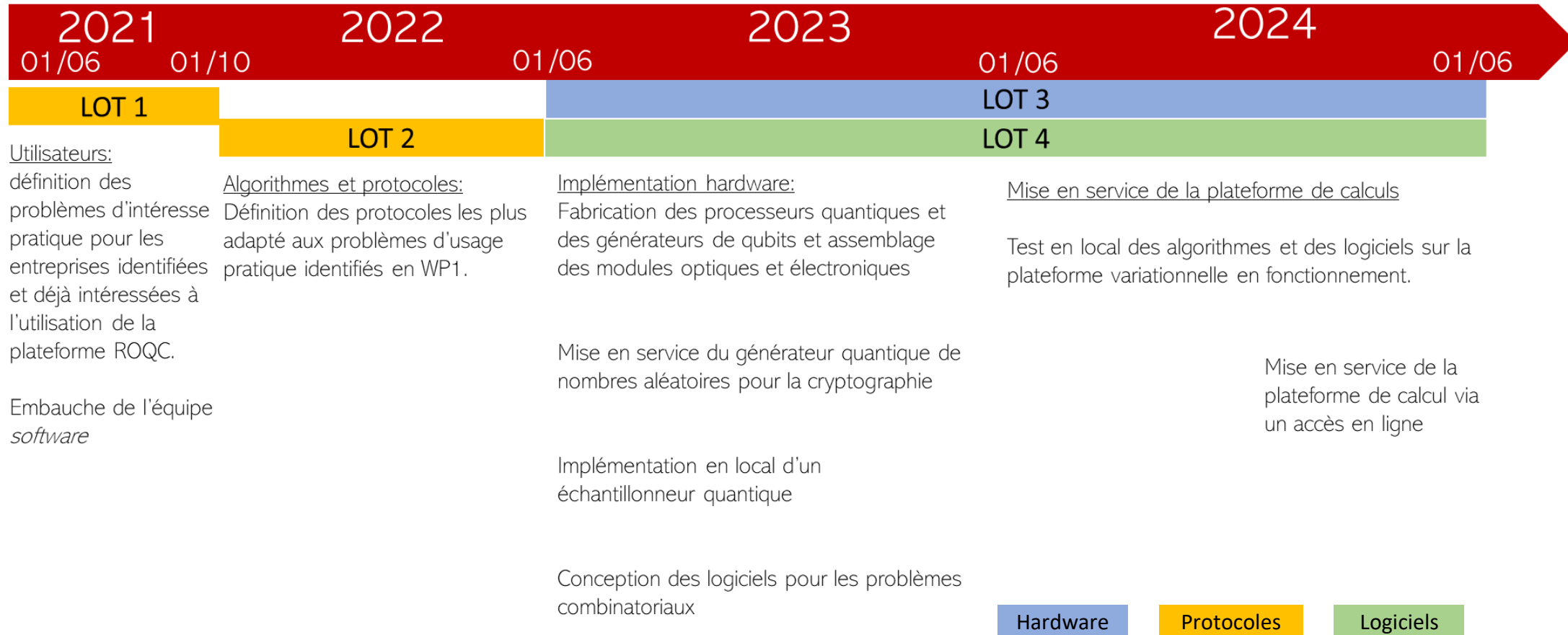
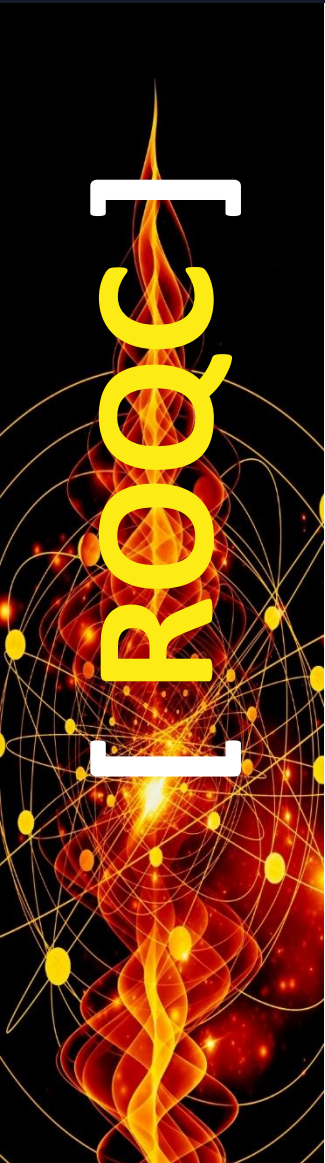



Résultats sur le projet

Perceval: Framework en source ouverte pour la photonique quantique – Concevoir, Simuler, et Contrôle de QPUs réels

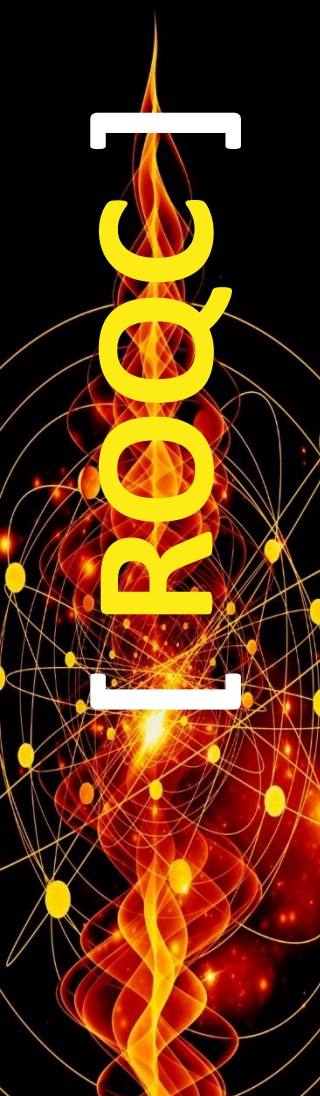

Shor's and Grover's Algorithms on a photonic processor

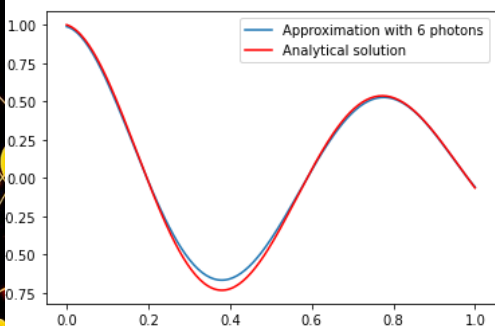

Solving Differential Equations



Up to 15 (20) photons on a laptop (supercomputer)

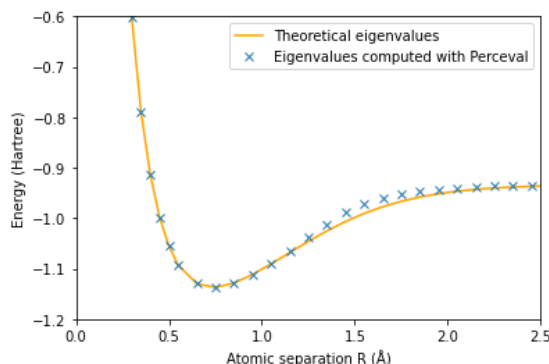

Simulation of Variational Quantum Eigensolvers

Compatible with



Partnership with

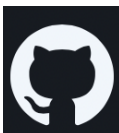

300 downloads per month, 2000+ downloads since March 2022

- **Fast evolution:** 6 majors releases in 6 months
- **Simple to use,** both for physicists and for computer scientists
- **Does not constrain the user to any framework-specific conventions** that are theoretically equivalent
- Provides **state-of-the-art optimized algorithms**
- Optimized simulation backends (sampling, **strong simulation**, matrix product state)
- Provides companion tools, like a unitary matrix toolkit, LaTeX or HTML rendering of algorithms
- Support **multiple encodings:** dual rail, polarization, qudit, time and hybrid encodings

Collaborative & Open Source

Perceval: Exemple d'échantillonnage

Boson Sampling

1. Defining circuit

```
n = 9 #number of photons at the input
m = 30 #number of modes
N = 10 #number of samplings
```

```
Unitary_10 = pcvl.Matrix.random_unitary(m)
```

Decomposition (optional, to verify)

```
mzi = (symb.BS() // (0, symb.PS(phi=pcvl.Parameter("φ_a")))
        // symb.BS() // (1, symb.PS(phi=pcvl.Parameter("φ_b"))))
pcvl.pdisplay(mzi)
```

```
Linear_Circuit_10 = pcvl.Circuit.decomposition(Unitary_10, mzi,
                                                phase_shifter_fn=symb.PS,
                                                shape="triangle")
```

2. Backend selection

```
Sampling_Backend = pcvl.BackendFactory().
    get_backend("CliffordClifford2017")
```

3. Choosing input

```
input_state = Generating_Input(n,m)
print("The input state:\n", input_state)
```

4. Outputting samples

```
print("The sampled outputs are:")
for _ in range(N):
    print(Sampling_Backend(Unitary_10).sample(input_state))
```

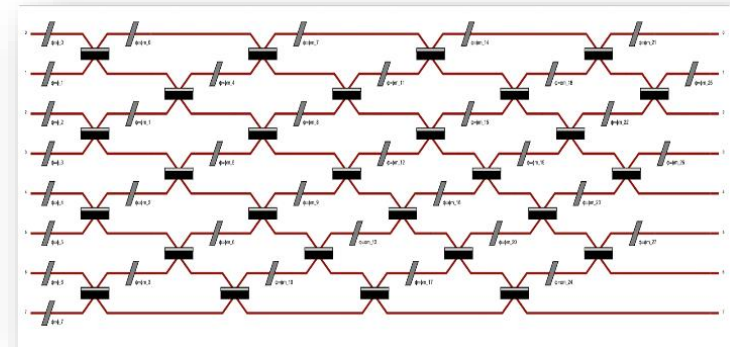

3.1: The input state:

```
|0,0,0,1,0,0,0,0,1,1,0,1,0,0,0,1,0,0,0,1,0,0,0,1,0,1,0,0,0,1>
```

4.1: The sampled outputs are:

```
|0,0,0,0,0,0,0,0,1,0,0,0,0,0,0,0,3,0,0,0,2,0,0,0,0,0,0,3,0>
|0,0,1,0,1,0,1,0,0,0,0,1,1,0,1,0,1,0,0,0,0,0,1,0,0,0,1,0,0,0>
|0,1,0,0,0,1,0,2,0,0,0,0,0,0,0,0,0,0,0,1,0,2,0,0,0,0,0,0,2>
|0,0,1,1,0,2,0,0,0,0,3,0,0,0,0,1,1,0,0,0,0,0,0,0,0,0,0,0,0,0>
|0,1,1,1,0,1,0,1,1,1,0,0,0,0,0,0,0,0,0,0,0,0,1,0,0,0,1,0,0,0>
|0,1,0,0,0,0,1,0,1,0,0,0,0,0,0,0,0,0,0,0,1,0,1,0,1,0,1,2,0,0>
|0,0,1,0,0,0,2,0,0,1,0,0,0,0,0,1,0,0,0,0,0,1,0,0,0,1,1,0,0,1>
|0,0,0,0,0,2,0,1,0,0,0,0,0,0,0,0,0,1,0,0,1,0,0,0,1,0,2,0,1>
|0,0,0,2,0,0,1,0,0,0,1,0,0,1,0,0,0,0,1,1,0,1,0,0,0,0,0,0,0,1>
|0,0,2,0,0,0,0,0,0,0,0,1,1,0,0,1,0,0,0,0,1,0,0,1,0,0,1,0,1,0>
```



Résultats sur le projet

CONFIDENTIALITY NOTICE - The contents of this presentation is intended solely for the addressee and may contain confidential and/or privileged information and may be legally protected from disclosure.

COPYRIGHT - Any reproduction of the images contained in this document without the authorization of the author is prohibited.

Perceval: Exemple de Variational Quantum Eigensolver, minimization d'une fonction de coût

3. Optimizing circuit parameters using a classical algorithm

```
tq = tqdm(desc='Minimizing...') #New progress bar
radius3=[]
E3=[]
init_param=[]

H=H3

for R in range(len(H)):
    #We try to find the ground state eigenvalue for each radius R
    radius3.append(H[R][0])
    if (init_param==[]):
        #
        init_param = [2*(np.pi)*random.random() for _ in List_Parameters]
    else:
        for i in range(len(init_param)):
            init_param[i]=VQE.get_parameters()[i]._value

# Finding the ground state eigen value for each H(R)
result=minimize(minimize_loss,init_param,method='Nelder-Mead')

E3.append(result.get('fun'))
tq.set_description('Finished' )
```

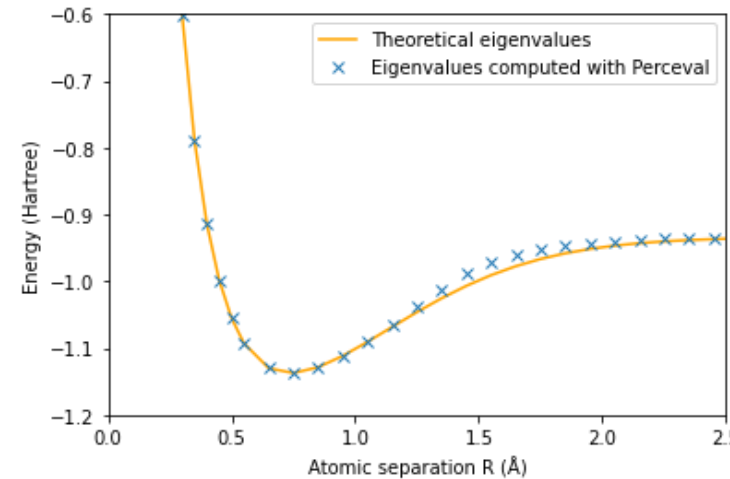

Finding the eigenstate of a two-atom system

For full code and other examples see

Welcome to the Perceval documentation!

Through a simple object-oriented Python API, Perceval provides tools for computing optical components like beamsplitters and phase shifters, defining single-photon and running simulations.

Perceval can be used to reproduce published experimental works or to experiment





Résultats sur le projet

Quandela Cloud – Des processeurs photoniques en ligne

QUANDELA Cloud

Log in Contact Us

QUANDELA Cloud
Making the future of computing brighter

Usage Explorer
Track your team activity, time spent on different platforms, remaining credits, and estimate costs

Quandela's cloud-based platform gives you access to photonic quantum computing develop and deploy algorithms that optimise solutions.

Get Started for Free

- qpu:ascella
QPU Ascella
Available
- sim:ascella
Ascella QPU Simulator
Available
- sim:clifford
Web simulator
Available

<https://cloud.quandela.com>

```

proc_slos = RemoteProcessor("QPU:Ascella", circuit, token)
proc_slos.with_input(pcvl.BasicState("|1,0,1,0,1,0>"))

slos_sampler = Sampler(proc_slos)
job2 = slos_sampler.sample_count.execute_async(count=100000)

with tqdm(total=1,) as tq:
    while not job2.is_completed():
        tq.update(job2.status.progress)
        time.sleep(.2)
    tq.close()

print(f"Job status = {job2.status()}")
results = job2.get_results()
for state, count in results.items():
    print(f"{state}: {count}")

```

Copyright Quandela @ 2022 - Terms of Service

Available

Achernar – specialized QRNG processor

Scaling up

Ascella – 5/6 qubit universal processor

Coming soon

Atair – 4 qubit specialized processor for QML

QUANDELA

UFOQO

Usine et Ferme d'Ordinateurs

Quantiques Optiques

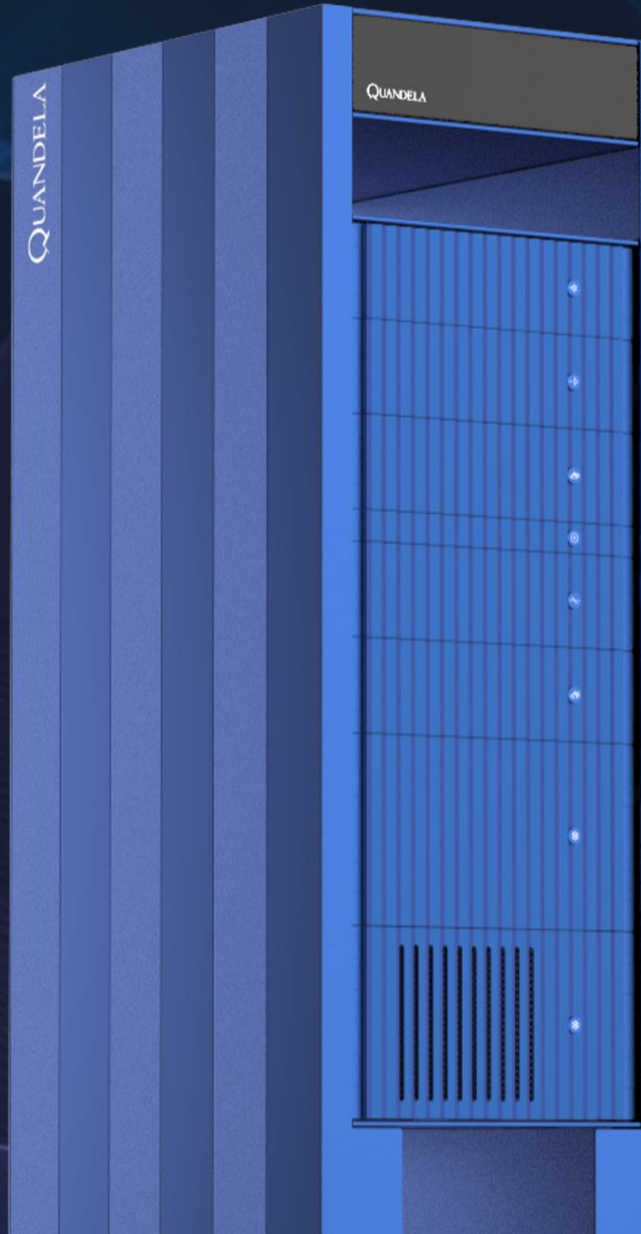



Projet UFOQO : premières Usine et Ferme d'Ordinateurs Quantiques Optiques en Europe

Depuis septembre 2022, Quandela loue 1400m² de locaux au sein du bâtiment BeOpen à Massy (Figure 1), dont près de 800m² consacrés au projet UFOQO.

Ce projet permettra à Quandela d'atteindre deux objectifs :

- le développement d'une première usine de production ;
- l'installation d'une première ferme d'ordinateurs quantiques photoniques, permettant de vendre des heures de calcul quantique à nos clients *via* le cloud



Figure 1 : entrée principale de la future usine de Quandela

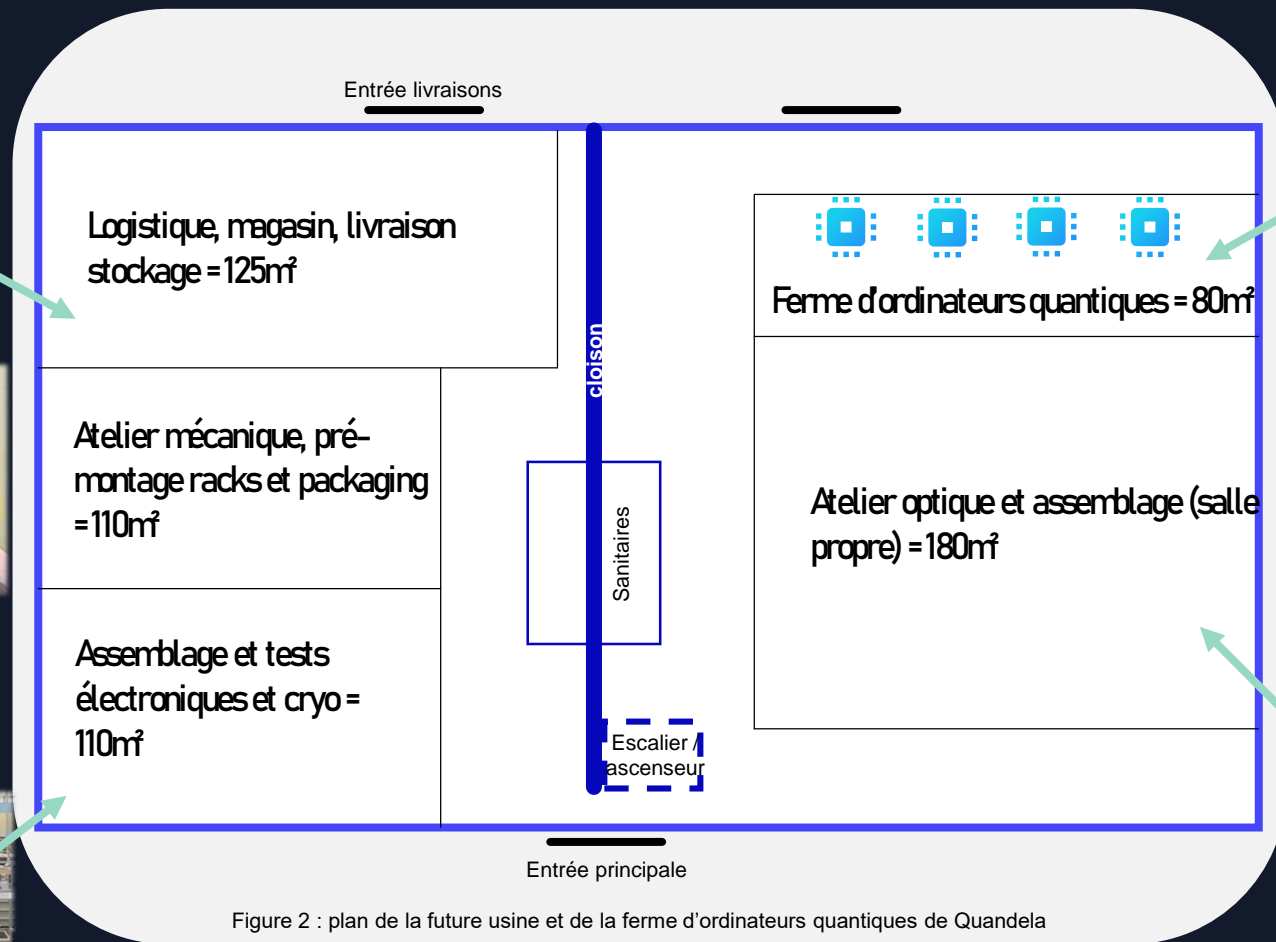

Figure 2 : futurs locaux de Quandela au sein du bâtiment BeOpen

- ✓ un espace de 80m² pour la ferme qui accueillera 4 ordinateurs quantiques photoniques
- ✓ l'atelier optique et assemblages de 180m² avec 12 postes
- ✓ un espace de 110m² dédié à l'assemblage et aux test électroniques et cryogéniques
- ✓ un atelier mécanique et packaging de 110m²
- ✓ un espace logistique, magasin, livraison et stockage de 125m²
- ✓ 110m² réservés à la circulation au sein de l'usine



Usine et ferme d'ordinateurs quantiques



Quandela, une ambition industrielle

Quandela disposera, dès le troisième trimestre 2023, d'une ligne de production pour ses sources de photons

Les sources seront directement livrées dans la future usine UFOQO où se feront l'assemblage des différents composants pour la fabrication des ordinateurs quantiques et les tests de production



Figure 3: salle blanche louée par Quandela au sein de l'IPVF



Figure 4: future usine de Quandela



Figure 5: représentation du bâtiment BeOpen à Massy

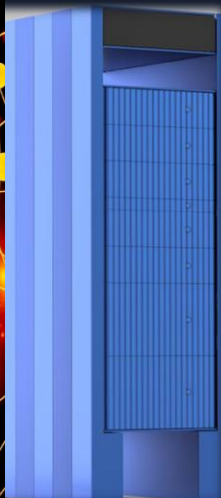

Un processus de fabrication détaillé et des flux logistiques plus importants pour :

- Accroître les quantités de QC (MosaiQ) produites
- Améliorer le contrôle du rendement et la qualité de la production.



- 4 MosaiQ dans la ferme Quandela d'ici mai 2025 pour vendre du temps de calcul quantique aux clients industriels *via* le cloud
- MosaiQ « on-premise » pour clients étatiques ou fournisseurs de cloud

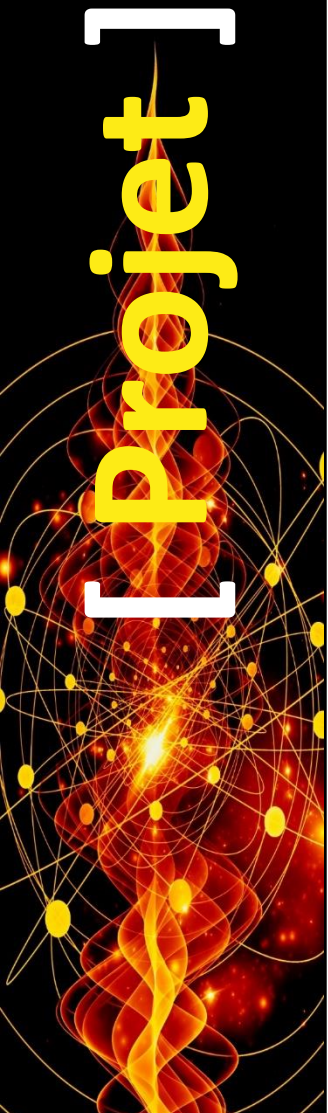

Sylvain Ferrari
Directeur Adjoint
ENSTA Paris



Davide Boschetto
Professeur
ENSTA Paris

EDUQUANTUM@Saclay

Davide Boschetto, Sylvain Ferrari
Institut Polytechnique de Paris / ENSTA Paris

8 décembre 2022

Principaux objectifs du projet : **Phase I** : déploiement d'une offre complète de formation continue et managériale sur les technologies quantiques au sein du centre Quantum-Saclay
Phase II : création d'un centre de simulation de calcul quantique, vitrine de l'excellence scientifique et Executive Education Center de Quantum-Saclay

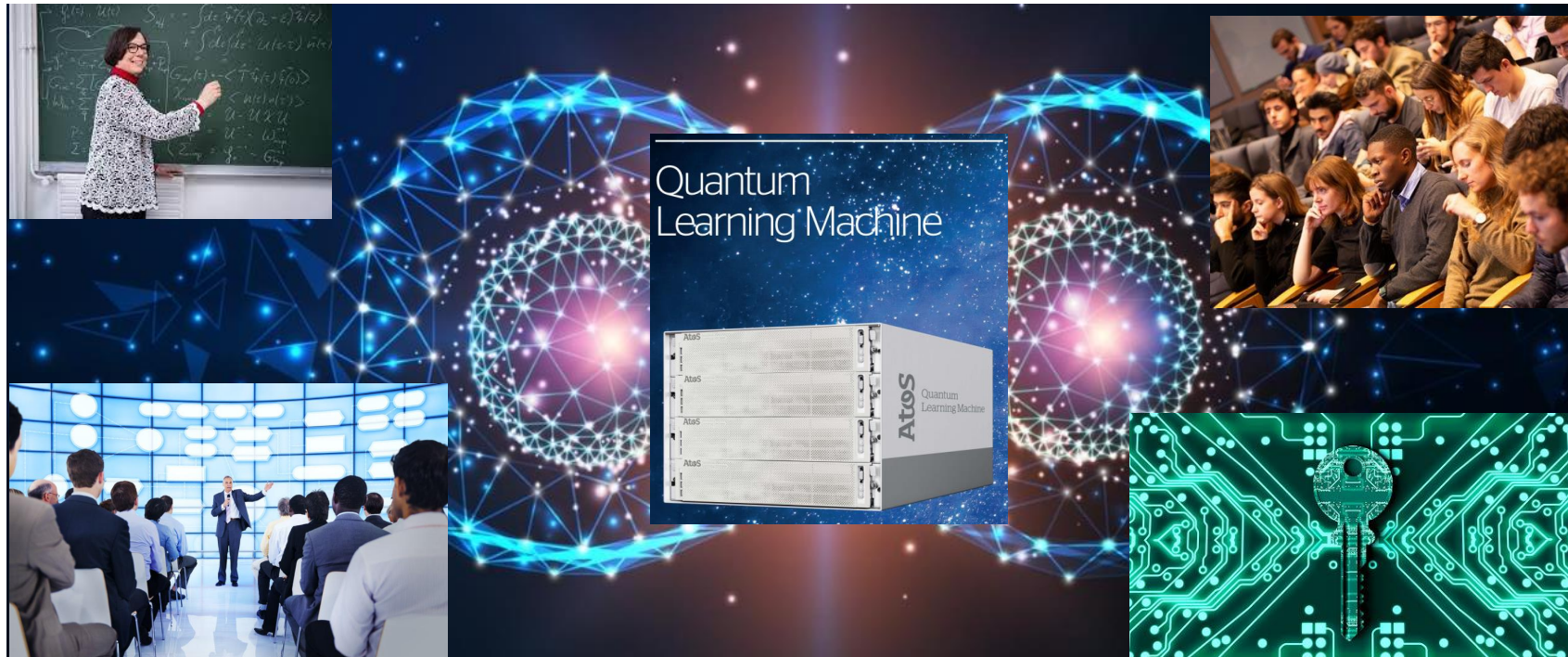

Fiche d'identité du projet

Partenaires académiques

Membres de QuanTEdu-France, Lauréat de l'AMI Compétences & Métiers d'Avenir

- **Institut Polytechnique de Paris (coordinateur)** : B. Deveaud, S. Ferrari
 - ENSTA Paris : D. Boschetto + EUROSÆ
 - Ecole Polytechnique : S. Biermann, L. Sanchez-Palencia + X-Exed
 - Télécom Paris : Romain Alléaume + Télécom Paris Exed
- **Université Paris-Saclay** : I. Demachy, M. Marsi

Contributeurs potentiels et soutiens au projet

- **ATOS** : P. Duluc, C. Allouche
- Pôle de compétitivité **Systematic Paris Region** : P. Duluc, E. Slamitz
- **ColibriTD** : L. Guiraud, H. Goudji
- **GENCI** : P. Lavocat, S. Requena, S. Mehr
- **CEA & Teratec** : C. Saguez, E. Vergnaud
- **ONERA** : A. Refloch, S. Schwartz
- **INRIA** : J-Y. Berthou, D. Simplot



Fiche d'identité du projet

quantum SACLAY



80 équipes de recherche au meilleur niveau mondial

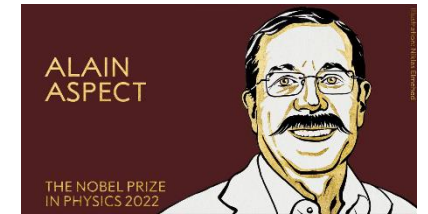

Communications quantiques et cryptographie post-quantique

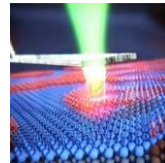

Capteurs quantiques et métrologie

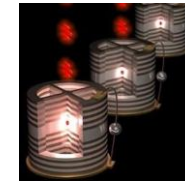

Photonique quantique

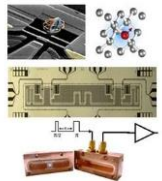

Circuits électriques quantiques

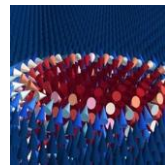

Spintronique

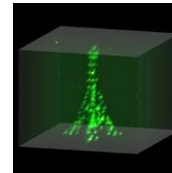

Simulation quantique



Matière quantique et topologique

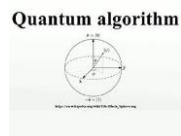

Algorithmique quantique

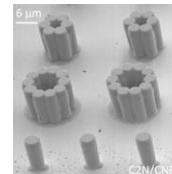

Nanotechnologies

Focus sur les compétences quantiques à IP Paris



Matériaux quantiques

Théorie : Silke Biermann (X, CPhT)
Karyn Le Hur (X, CPhT & CNRS)
Michel Ferrero (X, CPhT & CNRS)
Evgeny Stepanov (X, CPhT & CNRS)
Antoine Georges (X, CPhT/Collège de France/CCQ NYC)

Expériences : Davide Boschetto (ENSTA, LOA)
Emmanuel Péronne (ENSTA, LOA)
Guillaume Lambert (ENSTA, LOA)
Hamed Merdji (ENSTA, LOA & CEA)
Rodrigo Lopez-Martens (ENSTA, LOA)
Philippe Zeitoun (ENSTA, LOA)
Luca Perfetti (X, LSI)
Yannis Laplace (X, LSI)
Romain Grasset (X, LSI & CEA)
Fabian Cadiz (X, PMC)
Alistair Rowe (X, PMC)
Jacques Peretti (X, PMC)

...

Plateforme Optique pour L'Etude des Matériaux Quantiques (POETIQ)

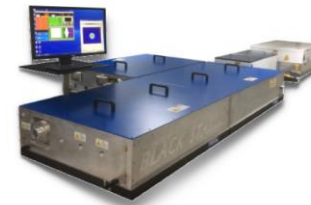

Focus sur les compétences quantiques à IP Paris



Matériaux quantiques

Théorie : Silke Biermann (X, CPhT)
Karyn Le Hur (X, CPhT & CNRS)
Michel Ferrero (X, CPhT & CNRS)
Evgeny Stepanov (X, CPhT & CNRS)
Antoine Georges (X, CPhT/Collège de France/CCQ NYC)

Expériences : Davide Boschetto (ENSTA, LOA)
Emmanuel Péronne (ENSTA, LOA)
Guillaume Lambert (ENSTA, LOA)
Hamed Merdji (ENSTA, LOA & CEA)
Rodrigo Lopez-Martens (ENSTA, LOA)
Philippe Zeitoun (ENSTA, LOA)
Luca Perfetti (X, LSI)
Yannis Laplace (X, LSI)
Romain Grasset (X, LSI & CEA)
Fabian Cadiz (X, PMC)
Alistair Rowe (X, PMC)
Jacques Peretti (X, PMC)

...

Information et simulation quantique

Laurent Sanchez Palencia (X, CPhT)
Daniel Malz (IP Paris & INRIA)

Circuits quantiques

Landry Bretheau (X, LSI)
Jean-Damien Pillet (X, LSI)
Joel Griesmar (X, PMC)

Informatique quantique et cryptographie

Romain Alléaume (Telecom Paris)
Peter Brown (Telecom Paris)
Cambyse Rouzé (IP Paris & INRIA)
Andrea Simonetto (ENSTA, UMA)

Communications et photonique quantiques

Yves Jaouen (Telecom Paris)
Isabelle Zaquine (Telecom Paris)
Frédéric Grillot (Telecom Paris)
Cédric Ware (Telecom Paris)

Chimie quantique

Julian Garrec (ENSTA, UCP)

Fiche d'identité du projet

+1 500 étudiants en formation initiale sur le quantique



Cycles ingénieurs - Cours de 1^{ère} et 2^{ème} année :

- Physique quantique (Ecole Polytechnique)	550 étudiants
- Physique quantique avancée (Ecole Polytechnique)	300 étudiants
- Optique quantique / Electrons dans les solides / Physique mésoscopique (Ecole Polytechnique)	90 étudiants
- Physique quantique (ENSTA Paris)	230 étudiants
- Nanosciences & Nanotechnologies (ENSTA Paris)	20 étudiants
- Physique quantique & Semi-conducteurs (Telecom Paris)	150 étudiants
- Information quantique & Calcul quantique (Telecom Paris)	15 étudiants

Cycles ingénieurs - Spécialisations de 3^{ème} année :

- Programme d'Approfondissement « Sciences et Technologies Quantiques » (Ecole Polytechnique)	20 étudiants
- Parcours « Quantum Engineering » (Telecom Paris) : 1 ^{ère} spécialisation ingénieur en France sur le quantique (2017)	5 étudiants

Bachelor - Cours

- Physique quantique (Ecole Polytechnique)	50 étudiants
- Mécanique quantique avancée (Ecole Polytechnique)	20 étudiants
- Electrons dans les solides (Ecole Polytechnique)	20 étudiants

Masters & PhD Tracks (IP Paris)

- Master « Quantum, Light, Materials and Nano Sciences » (QLMN)	60 étudiants
- Master « International Centre for Fundamental Physics » (ICLF)	
- Master « Dispositifs Quantiques »	
- Master « Quantum Physics » (ArTeQ)	
- PhD Track « Quantum Science and Technologies »	

Doctorat (IP Paris)

50 étudiants 88

Focus sur les compétences en formation continue et en formation managériale à IP Paris



- ✓ 5 structures dédiées à l'Executive Education
- ✓ +80 personnes travaillant dans ces structures
- ✓ Chiffre d'affaires annuel de 20 M€
- ✓ +2 000 intervenants extérieurs
- ✓ +300 enseignants-chercheurs d'IP Paris intervenant dans les modules de formation
- ✓ +8 500 participants chaque année à nos programmes Exed
- ✓ Expérience déjà bien établie dans la pédagogie **combinant compétences en management et technologie** (ex. double diplôme X-HEC)
- ✓ Un positionnement reconnu sur les **technologies innovantes**, le **management de la technologie**, l'**entrepreneuriat** et les **formations managériales**
- ⇒ Des programmes Exed existants en informatique quantique, cryptographie post-quantique, physique quantique...
- ⇒ Plusieurs entreprises (défense, transport, énergie, ESN...) intéressées par de nouveaux programmes Exed sur le quantique



Déploiement d'une offre complète de formation continue et managériale sur les technologies quantiques au sein de Quantum-Saclay

Public visé : ingénieurs, managers, dirigeants d'entreprises, créateurs de startups, enseignants-chercheurs

Les ingénieurs, managers et dirigeants d'entreprises, créateurs de startups, enseignants-chercheurs seront confrontés à un véritable changement de paradigme, vis-à-vis de l'utilisation des nouveaux concepts liés à la vision quantique de la réalité, ainsi qu'à la manipulation de ces concepts pour l'utilisation technologique. Leur formation est donc indispensable afin d'atteindre l'objectif affiché par le gouvernement.

Réalisation de formations adaptées à chacun des publics :

1. Formations techniques (modules spécialisés) pour les ingénieurs qui se destinent à l'utilisation des technologies quantiques
2. Formations de sensibilisation pour les managers
3. Séminaires pour des cadres dirigeants et ComEx
4. « Learning Expeditions » à destination des équipes de direction
5. Formations managériales pour les créateurs de start-up et enseignants-chercheurs porteurs de projets innovants dans le quantique





Budget - Phase I



WP1 Conception de modules de formation continue et managériale	1 500 k€
WP2 Ingénierie pédagogique	500 k€
WP3 Plateforme pédagogique d'enseignement à distance	2 000 k€
WP4 Communication / Marketing / Commercialisation	300 k€
Budget EDUQUANTUM@Saclay – Phase I (4 ans)	4,3 M€

8 décembre 2022

**Lancement officiel de la nouvelle offre « Executive Education »
de l'Institut Polytechnique de Paris sur le quantique**

1. Formations techniques (modules spécialisés)

- Physique Quantique
- Capteurs Quantiques
- Matériaux Quantiques
- Ordinateur Quantique et Calcul Quantique
- Cryptographie Quantique

2. Formations de sensibilisation pour les managers, ingénieurs, techniciens, scientifiques...

- Comprendre l'Informatique Quantique (prochaine session les 15 & 16 décembre 2022)

3. Séminaires pour des cadres dirigeants et ComEx

4. « Learning Expeditions » à destination des équipes de direction

Projet EDUQUANTUM

Phase II

Création d'un centre de simulation de calcul quantique, vitrine de l'excellence scientifique et centre d'Executive Education de Quantum-Saclay

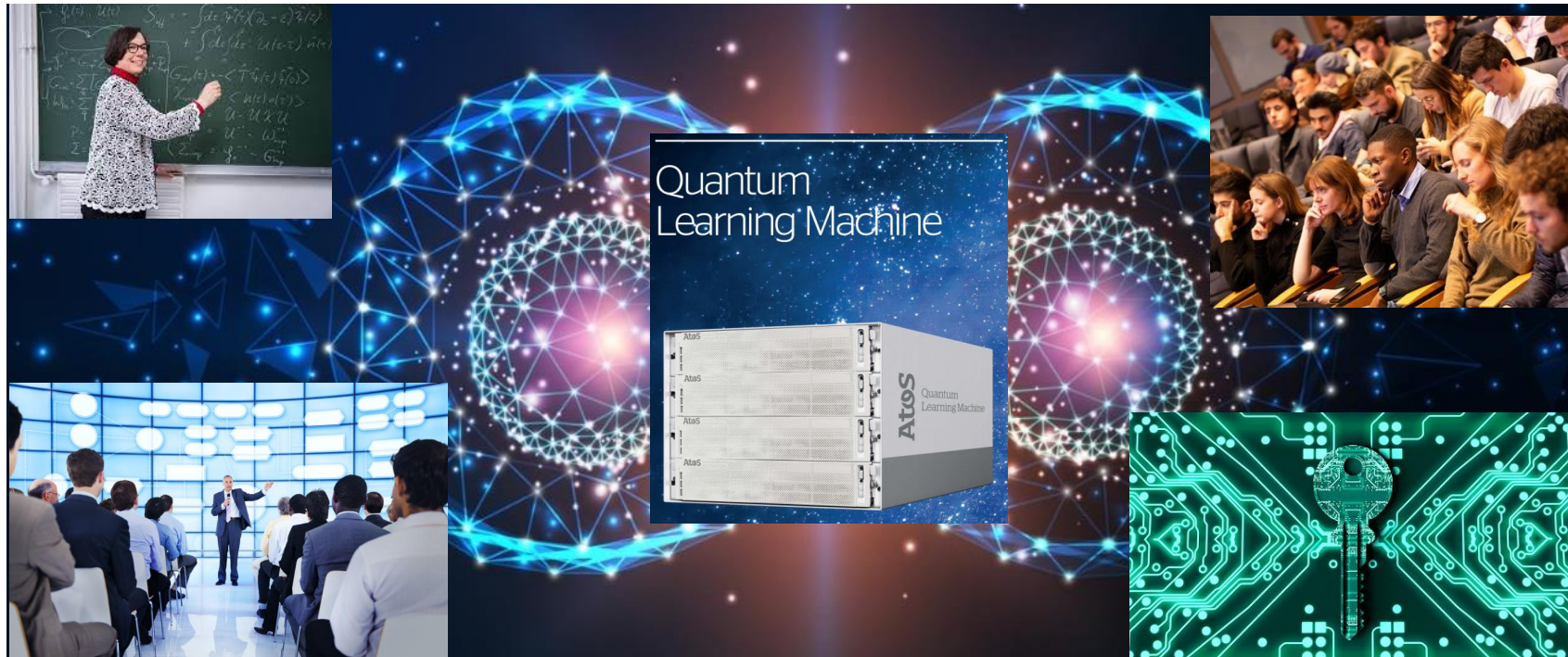



EDUQUANTUM Phase II

- Création d'un centre de calcul quantique, **EDUQUANTUM**, basé sur le simulateur d'ordinateur quantique conçu par ATOS (Quantum Learning Machine) : moyens de calcul mis à disposition de la communauté scientifique



EDUQUANTUM

Phase II



- Création d'un centre de calcul quantique, **EDUQUANTUM**, basé sur le simulateur d'ordinateur quantique conçu par ATOS (Quantum Learning Machine) : moyens de calcul mis à disposition de la communauté scientifique
- Utilisation de ce centre de calcul comme vitrine d'excellence pour réaliser des formations sur les technologies quantiques adaptées à différents publics :



EDUQUANTUM Phase II



- Création d'un centre de calcul quantique, **EDUQUANTUM**, basé sur le simulateur d'ordinateur quantique conçu par ATOS (Quantum Learning Machine) : moyens de calcul mis à disposition de la communauté scientifique
- Utilisation de ce centre de calcul comme vitrine d'excellence pour réaliser des formations sur les technologies quantiques adaptées à différents publics :

Formation continue & managériale (*développé en Phase I*)

Formation initiale



EDUQUANTUM

Phase II



- Création d'un centre de calcul quantique, **EDUQUANTUM**, basé sur le simulateur d'ordinateur quantique conçu par ATOS (Quantum Learning Machine) : moyens de calcul mis à disposition de la communauté scientifique
- Utilisation de ce centre de calcul comme vitrine d'excellence pour réaliser des formations sur les technologies quantiques adaptées à différents publics :

Formation continue & managériale (*développé en Phase I*)

Formation initiale

- Développement de sujets d'exercices et de travaux pratiques en lien avec la recherche en physique quantique théorique et expérimentale, ainsi qu'en lien avec le calcul quantique. Formalisation de problèmes concernant la physique quantique, conjointement avec des simulations via le centre de calcul quantique et des tests expérimentaux via les plateformes d'IP Paris (optique, matière condensée, circuits supraconducteurs, etc.).



EDUQUANTUM

Phase II



- Création d'un centre de calcul quantique, **EDUQUANTUM**, basé sur le simulateur d'ordinateur quantique conçu par ATOS (Quantum Learning Machine) : moyens de calcul mis à disposition de la communauté scientifique
- Utilisation de ce centre de calcul comme vitrine d'excellence pour réaliser des formations sur les technologies quantiques adaptées à différents publics :

Formation continue & managériale (*développé en Phase I*)

Formation initiale

- Développement de sujets d'exercices et de travaux pratiques en lien avec la recherche en physique quantique théorique et expérimentale, ainsi qu'en lien avec le calcul quantique. Formalisation de problèmes concernant la physique quantique, conjointement avec des simulations via le centre de calcul quantique et des tests expérimentaux via les plateformes d'IP Paris (optique, matière condensée, circuits supraconducteurs, etc.).
- Création de bibliothèques spécifiques pour le calcul quantique



Le centre EDUQUANTUM, où ?

**Un centre de calcul dédié à la
formation continue, oui !
Mais où ?**

Un centre de calcul dédié à la
formation continue, oui !
Mais où ?

Proposition d'Emplacement :

Institut Polytechnique de Paris / ENSTA Paris

Batterie de l'Yvette, 181 chemin de la Hunière et des Joncherettes, Palaiseau

Plusieurs locaux seront bientôt disponibles à proximité du Laboratoire d'Optique Appliquée (LOA), suite au déménagement de l'Unité de Mécanique (UME) d'ENSTA Paris dans le nouveau bâtiment mécanique d'IP Paris.

Le centre EDUQUANTUM, où ?

EDUQUANTUM :
Centre de formation
dédié aux technologies
quantiques



Proposition d'Emplacement : Batterie de l'Yvette, 181 chemin de la Hunière et des Joncherettes, Palaiseau
Plusieurs locaux seront bientôt disponibles à proximité du Laboratoire d'Optique Appliquée (LOA), suite au déménagement de l'Unité de Mécanique (UME) d'ENSTA Paris dans le nouveau bâtiment mécanique d'IP Paris.

Qu'est qu'il y aura
dans EDUQUANTUM ?

Qu'est qu'il y aura
dans EDUQUANTUM ?



Qu'est qu'il y aura dans EDUQUANTUM ?

Dans EDUQUANTUM: Un simulateur d'ordinateur quantique ATOS, ainsi que plusieurs terminaux (vidéo+clavier) directement connectés.

Le nombre de terminaux sera à dimensionner par rapport à la capacité spatiale des locaux, ainsi que la capacité de parallélisation de la QLM.

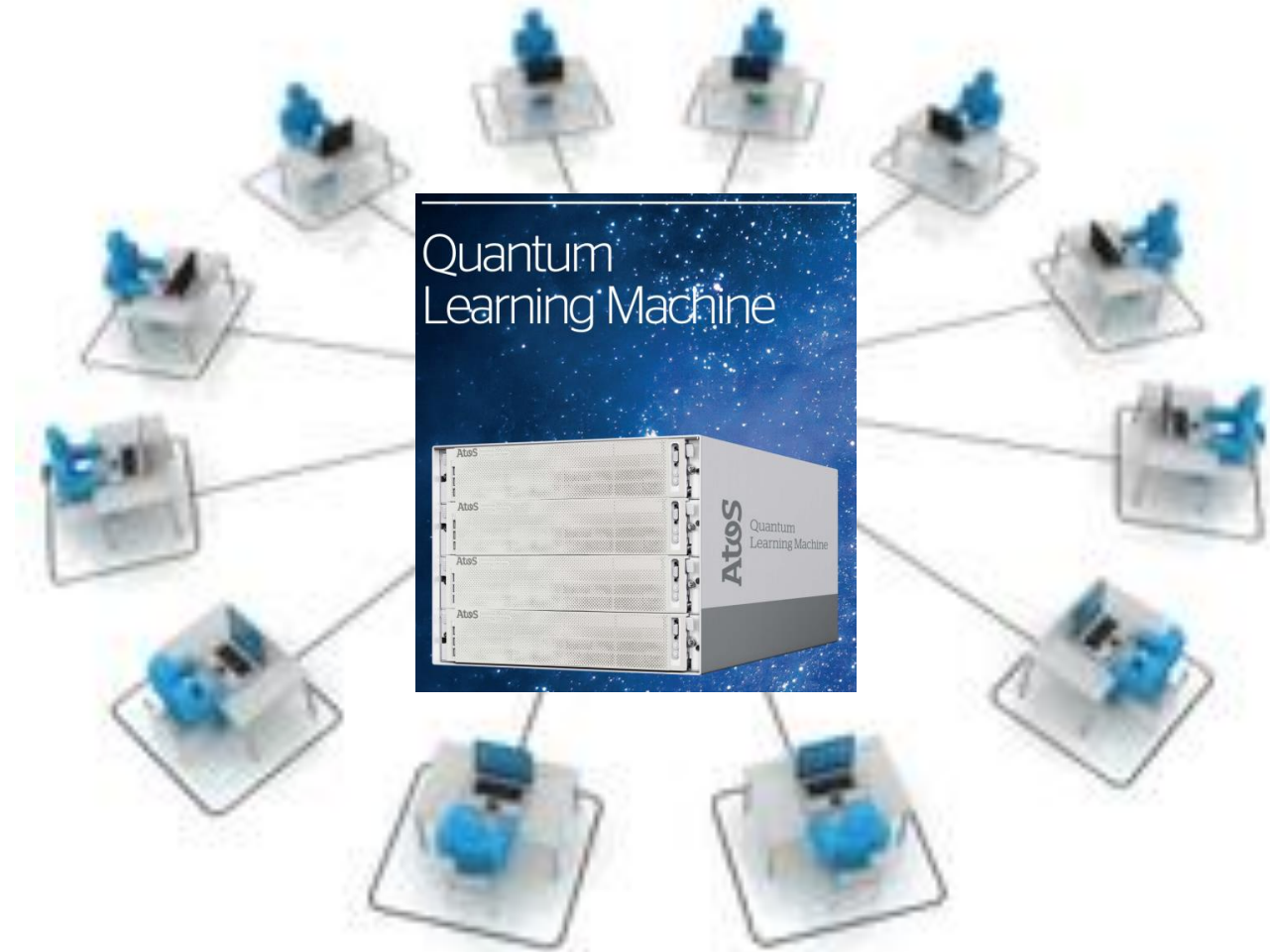

Le centre EDUQUANTUM, pour qui ?

1) Formation continue pour les ingénieurs, managers et dirigeants d'entreprises et de startups

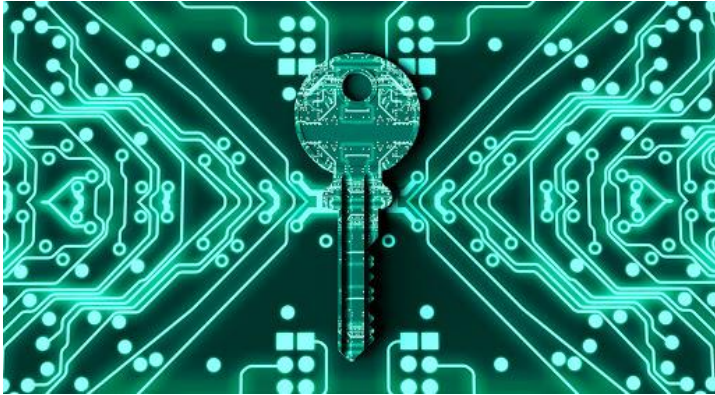

2) Formation initiale pour les élèves ingénieurs et étudiants d'IP Paris et d'autres Universités



Objectif affiché par le gouvernement : 10 000 ingénieurs formés aux technologies quantiques d'ici 2030.

Le centre EDUQUANTUM, pour qui ?

1) Formation continue pour les ingénieurs, managers et dirigeants d'entreprises et de startups

Les ingénieurs, managers et dirigeants d'entreprises seront confrontés à un véritable changement de paradigme, vis-à-vis de l'utilisation des nouveaux concepts liés à la vision quantique de la réalité, ainsi qu'à la manipulation de ces concepts pour l'utilisation technologique. Leur formation est donc indispensable afin d'atteindre l'objectif affiché par le gouvernement.



Objectif affiché par le gouvernement : 10 000 ingénieurs formés aux technologies quantiques d'ici 2030.

2) Formation initiale pour les élèves ingénieurs et étudiants d'IP Paris et d'autres Universités



1) Formation continue pour les ingénieurs, managers et dirigeants d'entreprises et de startups

Les ingénieurs, managers et dirigeants d'entreprises seront confrontés à un véritable changement de paradigme, vis-à-vis de l'utilisation des nouveaux concepts liés à la vision quantique de la réalité, ainsi qu'à la manipulation de ces concepts pour l'utilisation technologique. Leur formation est donc indispensable afin d'atteindre l'objectif affiché par le gouvernement.

Réalisation de formations adaptées à différents publics :

1. Formations techniques (modules spécialisés) pour les ingénieurs qui se destinent à l'utilisation des technologies quantiques
2. Formations de sensibilisation pour les managers
3. Séminaires pour des cadres dirigeants et ComEx
4. « Learning Expeditions » à destination des équipes de direction
5. Formations managériales pour les créateurs de start-up et enseignants-chercheurs porteurs de projets innovants dans le quantique

Objectif affiché par le gouvernement : 10 000 ingénieurs formés aux technologies quantiques d'ici 2030.

2) Formation initiale pour les élèves ingénieurs et étudiants d'IP Paris et d'autres Universités



1) Formation continue pour les ingénieurs, managers et dirigeants d'entreprises et de startups

Les ingénieurs, managers et dirigeants d'entreprises seront confrontés à un véritable changement de paradigme, vis-à-vis de l'utilisation des nouveaux concepts liés à la vision quantique de la réalité, ainsi qu'à la manipulation de ces concepts pour l'utilisation technologique. Leur formation est donc indispensable afin d'atteindre l'objectif affiché par le gouvernement.

Réalisation de formations adaptées à différents publics :

1. Formations techniques (modules spécialisés) pour les ingénieurs qui se destinent à l'utilisation des technologies quantiques
2. Formations de sensibilisation pour les managers
3. Séminaires pour des cadres dirigeants et ComEx
4. « Learning Expeditions » à destination des équipes de direction
5. Formations managériales pour les créateurs de start-up et enseignants-chercheurs porteurs de projets innovants dans le quantique

Objectif affiché par le gouvernement : 10 000 ingénieurs formés aux technologies quantiques d'ici 2030.

2) Formation initiale pour les élèves ingénieurs et étudiants d'IP Paris et d'autres Universités

L'existence d'un centre de calcul quantique au **cœur du campus Saclay** va **éveiller de nouvelles vocations** chez les jeunes ingénieurs et étudiants, qui auront le privilège d'utiliser un système informatique unique dans son genre.

Ils pourront participer à des projets en lien direct avec des partenaires industriels au cours de leurs études.



Le centre EDUQUANTUM, pour qui ?

- Ce centre de calcul sera également utilisé pour tester de nouveaux algorithmes et pour essayer de résoudre des questions encore ouvertes scientifiquement.
- Ces problématiques feront l'objet de cas d'études pour la formation et l'entraînement des apprenants en calcul quantique.
- Centre ouvert et partagé, les moyens de calcul seront mis à disposition de la communauté scientifique.

Description théorique (CPHT, Ecole Polytechnique)



Simulation des résultats (Centre EDUQUANTUM)

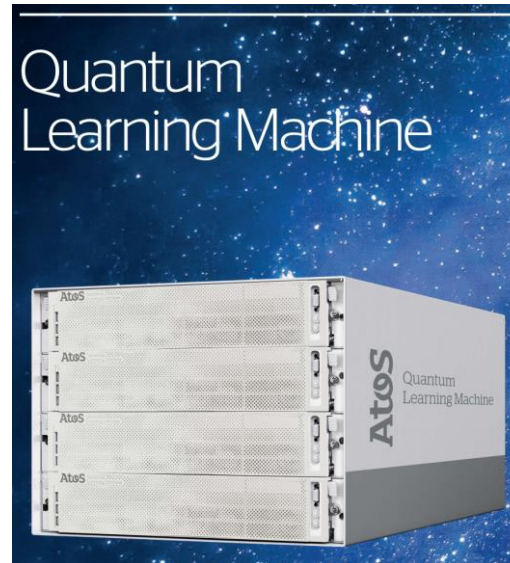

Test expérimental (ENSTA/Ecole Polytechnique)

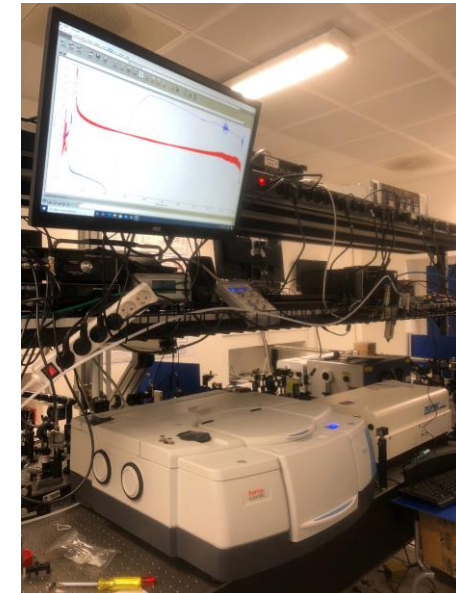

Albert, j'ai une nouvelle idée mais
je ne sais pas où la tester.

Chez EDUQUANTUM.





Budget - Phase II



WP5 Installation du centre de calcul quantique	1 000 k€
WP6 Veille de l'état de l'art du calcul quantique	20 k€
WP7.1 Projets et cas d'usage, simulations et banc de tests hardware	2 000 k€
WP7.2 Projets de thèse liés aux cas d'usage d'intérêt industriel	300 k€
WP8 Modules de formation initiale en calcul quantique pour les cursus ingénieurs	300 k€
WP9 Développement de bibliothèques particulières	1 500 k€
WP10.1 Physique quantique avancée, partie théorique	1 000 k€
WP10.2 Physique quantique avancée, partie expérimentale	1 000 k€
WP11 Valorisation de la propriété intellectuelle	400 k€
Budget EDUQUANTUM@Saclay – Phase II	7,52 M€

Conclusions

- Le projet EDUQUANTUM naît dans un contexte extrêmement favorable, et il propose des objectifs parfaitement en ligne avec les souhaits gouvernementaux.
- Le consortium offre au projet une grande probabilité de réussite. La complémentarité des partenaires, ainsi que leurs compétences reconnues au niveau international, sont un facteur clé pour la réussite de ce projet.
- Aujourd'hui, il n'existe aucun centre de formation dédié aux technologies quantiques en France, en lien avec des applications. EDUQUANTUM vient combler ce manque.
- EDUQUANTUM sera une vitrine d'excellence pour les membres du consortium, et contribuera fortement à leur visibilité internationale, ainsi qu'au rayonnement de l'engagement académique et industriel français envers les technologies quantiques.

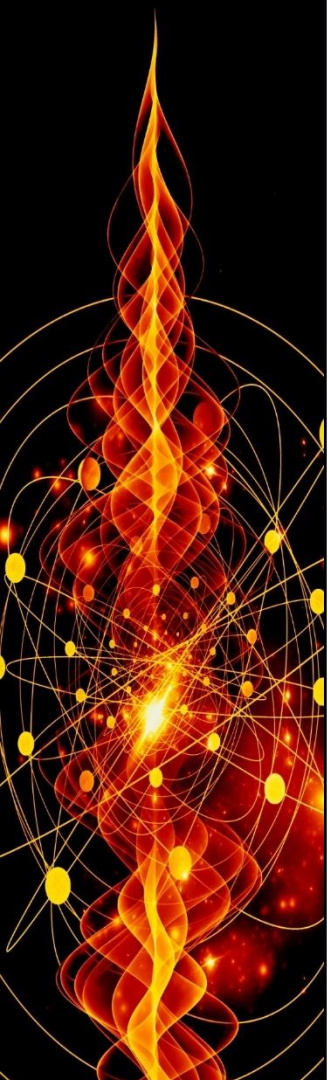

PAUSE DÉJEUNER
ON SE RETROUVE A 14H00

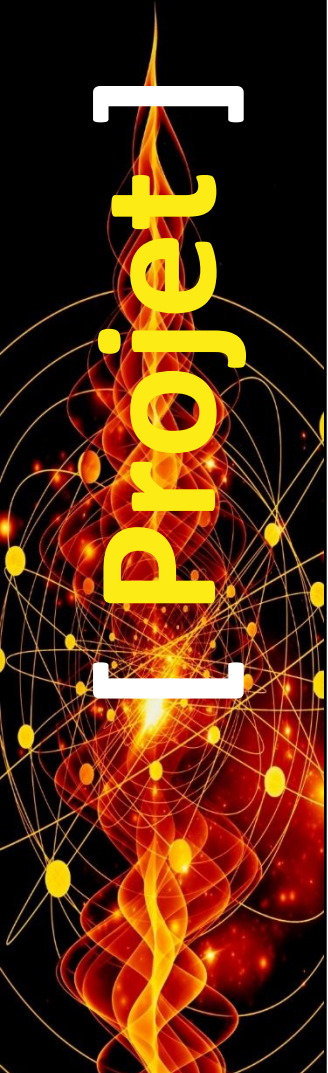

Laurent Guiraud
Co-Fondateur
Colibritd



Alain Refloch
Chargé de mission
Onera



Philippe Duluc
SVP, CTO big data & security
Atos

Journée Quantique Systematic – Teratec – Genci
8 décembre 2022

vulqain



COLIBRID



Objectifs & Partenariats

Plateforme de Simulation de Combustion hybride Quantique / Classique

Fonctionnalités

- Interface WEB pour test rapides
- API pour integration systems existants
- Multiplateforme matériel quantique
- Hybridation classique quantique au travers QLM Atos
- Développement et maintenance des algorithmes quantiques issus de la recherche académique

Marché

- Aéronautique
 - Optimisation des réacteurs
 - Enjeux neutralité carbone à l'horizon 2050
- Défense
 - Optimisation de la combustion pour tout type de réacteurs
 - Avions, missiles, bateaux...
- Autres industries
 - Automobile
 - ...

Partenaires



Simulation Quantique hybride
HPC QLM



Expertise **ONERA** en
combustion (aérobie,
propulsion fusée, stato
réacteur, ...)



**Aerospace & Defense
Accelerator** (Safran, Onera,
CNES, AID, MBDA, Naval)

Plateforme de Simulation de Combustion hybride Quantique / Classique

Calcul Quantique

- Optimisation Combinatoire
- Equations aux dérivées partielles
 - 98 % CPU
 - Consommation Energie

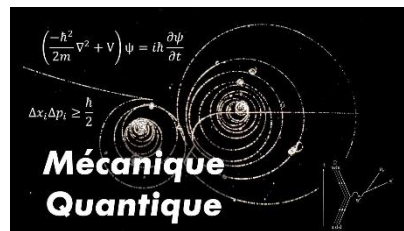

Cible

- CFD Aéronautique et combustion
- **1 PaQ IdF** Aérodynamique avec PASQAL et AIRBUS accompagné par Ter@tec
- **1 PaQ IdF** combustion avec QUANDELA et MBDA accompagné par GENCI

Objectifs



Besoins en **Combustion** très supérieur aux besoins en Aérodynamique



- Volonté d'être agnostique vis-à-vis du *hardware*
- Simulateur QLM d'ATOS

Pas d'avantage quantique sans algorithme quantique

- Recherche de compétences algorithmiques
- **Court terme** : NISQ – hybride – VQA – QML
- **Objectifs** : compréhension, acculturation
- **Long terme** : LSQ – Monte Carlo

Plateforme de Simulation de Combustion hybride Quantique / Classique

Calcul Quantique

- Cas d'usages proches des besoins clients HPC actuels
- Enrichissement de l'offre QLM
- Partenariat R&D

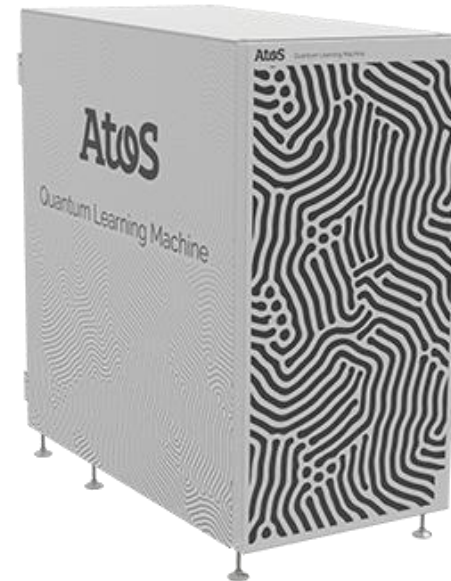
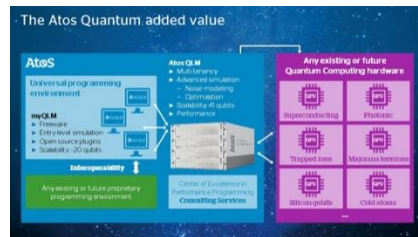

Cible

- Client HPC existant monde aéronautique et Défense
- Initiative HQI plan quantique Français

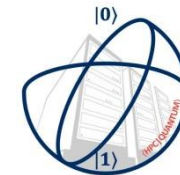

Les Objets du Projet

- La combustion est présente dans plusieurs secteurs d'activités humains
 - Une interaction entre les réactions chimiques et thermodynamiques
 - Un phénomène hautement non linéaire (turbulent) qui pose défis computationnels
- C'est possible d'utiliser la puissance de l'informatique quantique pour y faire face
 - Soit pour résoudre des équations du type **Navier-Stokes**
 - Ou faire des simulations Monte Carlo
- Meilleures simulations de combustion
 - Émissions de carbone réduites
 - Moteurs et turbines plus sûrs
 - Empreinte énergétique plus faible des centres HPC
- Néanmoins, les ordinateurs quantiques actuels ne sont pas idéals: l'ère NISQ
- Il faut trouver des algorithmes quantiques compatibles avec le *hardware* disponible

Navier–Stokes momentum equation (*convective form*)

$$\rho \frac{D\mathbf{u}}{Dt} = \rho \left(\frac{\partial \mathbf{u}}{\partial t} + \mathbf{u} \cdot \nabla \mathbf{u} \right) = -\nabla p + \nabla \cdot \left\{ \mu \left(\nabla \mathbf{u} + (\nabla \mathbf{u})^T - \frac{2}{3} (\nabla \cdot \mathbf{u}) \mathbf{I} \right) + \zeta (\nabla \cdot \mathbf{u}) \mathbf{I} \right\} + \rho \mathbf{g}.$$

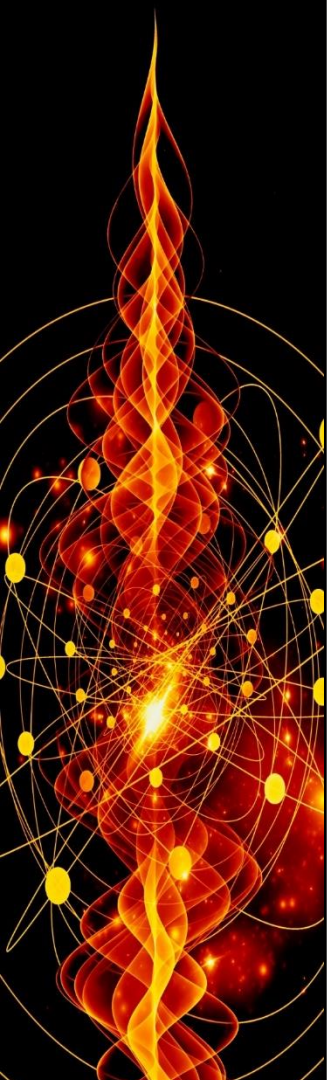

Résultats Attendus

- Démontrer un cas simple 1D d'une structure de flamme
- Développer un algorithme hybride (classique-quantique) résistant au *bruit* pour résoudre des Equations aux dérivées partielles (EDPs).
- Implémenter l'algorithme dans le simulateur Quantum Learning Machine (QLM) fourni par ATOS
- Évaluer l'algorithme par rapport à
 - Résistance aux différents types de bruit
 - Scalabilité comparé aux méthodes classiques
 - Consommation énergétique
- Permettre de visualiser les résultats obtenus par le solveur quantique

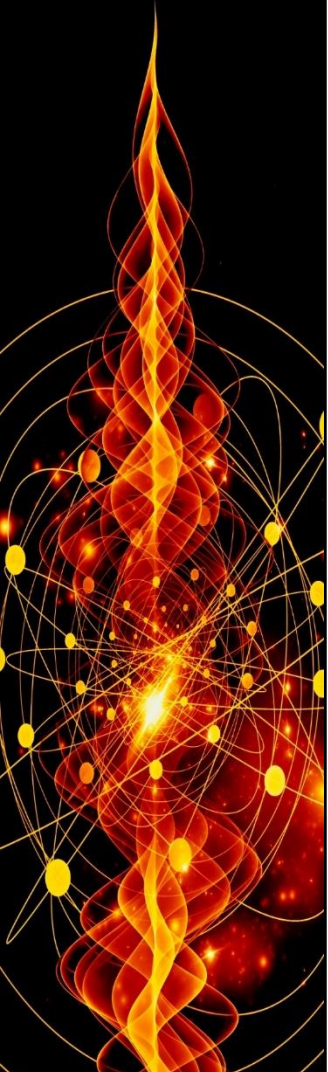

Verrous

- Peu d'études sur les algorithmes quantiques pour la combustion
- Bruit (taux d'erreur) des circuits quantiques variationnels (VQC) profonds
- Réduire la profondeur des VQC sans perte de généralité
- Garantir une scalabilité (théorique) qui justifie l'adoption des algorithmes quantiques pour la résolution des EDPs

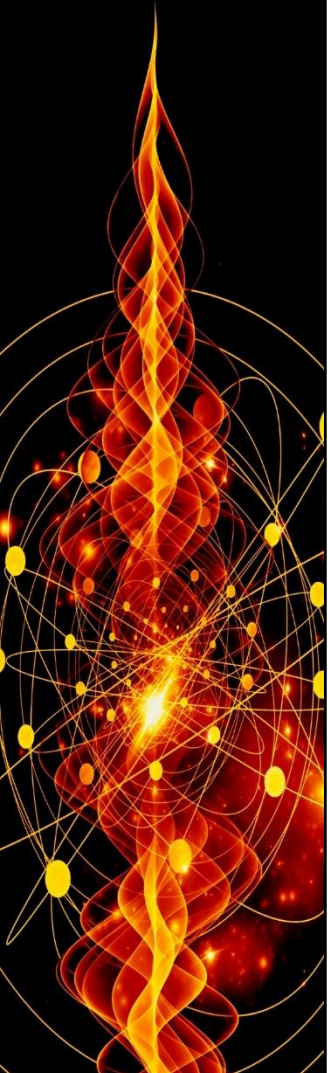

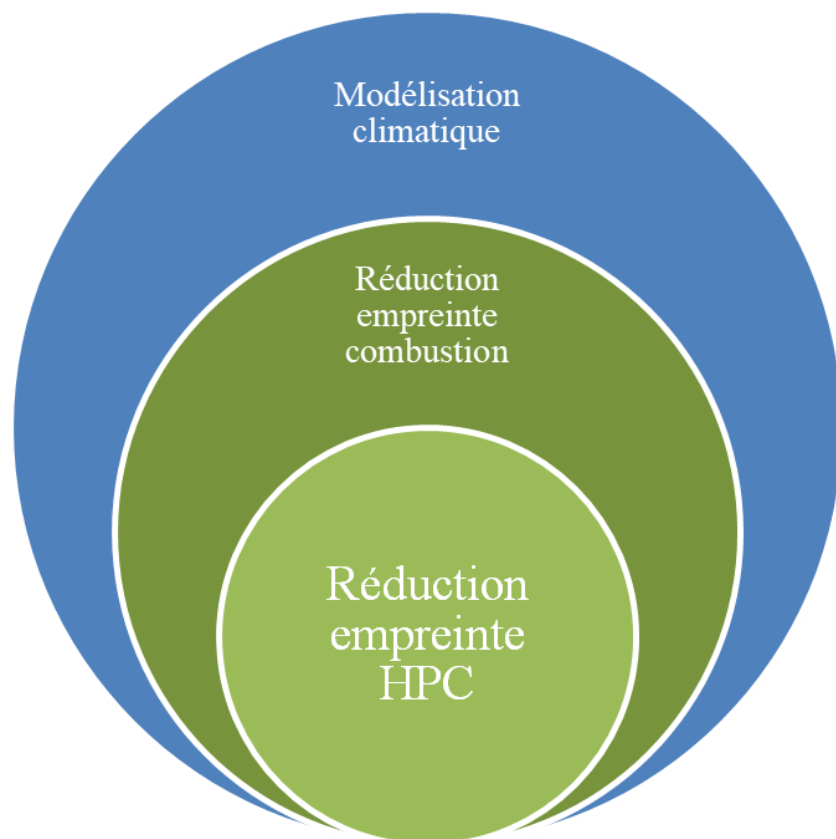

- **Court Terme** : Réduction consommation IT HPC
- dans le NISQ (<2 ans)
- **Moyen Terme** : Amélioration processus combustion
- des centaines de qubits *idéaux*
- **Long terme** : Modélisation climatique
- *large scale quantum* (LSQ)

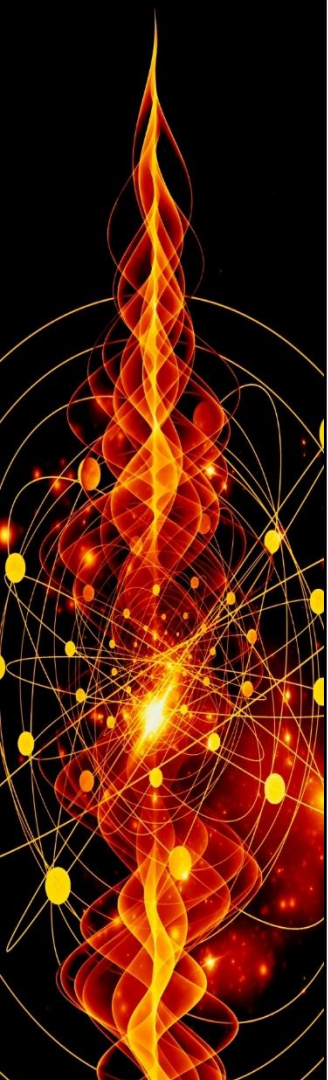

Impacts Economiques

Partenaire	Impacts
ColibrITD	Accélération développement plateforme quantique self service. 2 chercheurs CDI + 2 stagiaires sur IDF. 20+ chercheurs sur les 2 ans à venir sur IDF.
ONERA	Appropriation des technologies logiciels quantiques en lien avec le QTech et impact indirect sur montée en compétence DGA sur technologies quantiques.
ATOS	Cas d'usage en lien avec stratégie hybride HPC/Quantique.

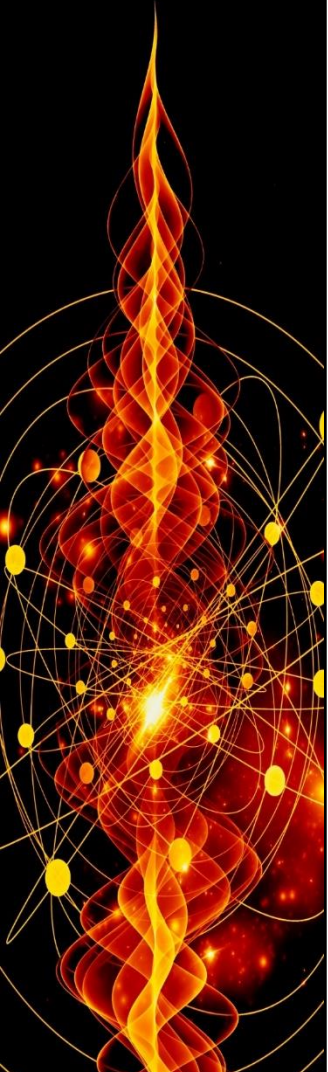

Planning et lots dans le cadre de la soumission RAPID

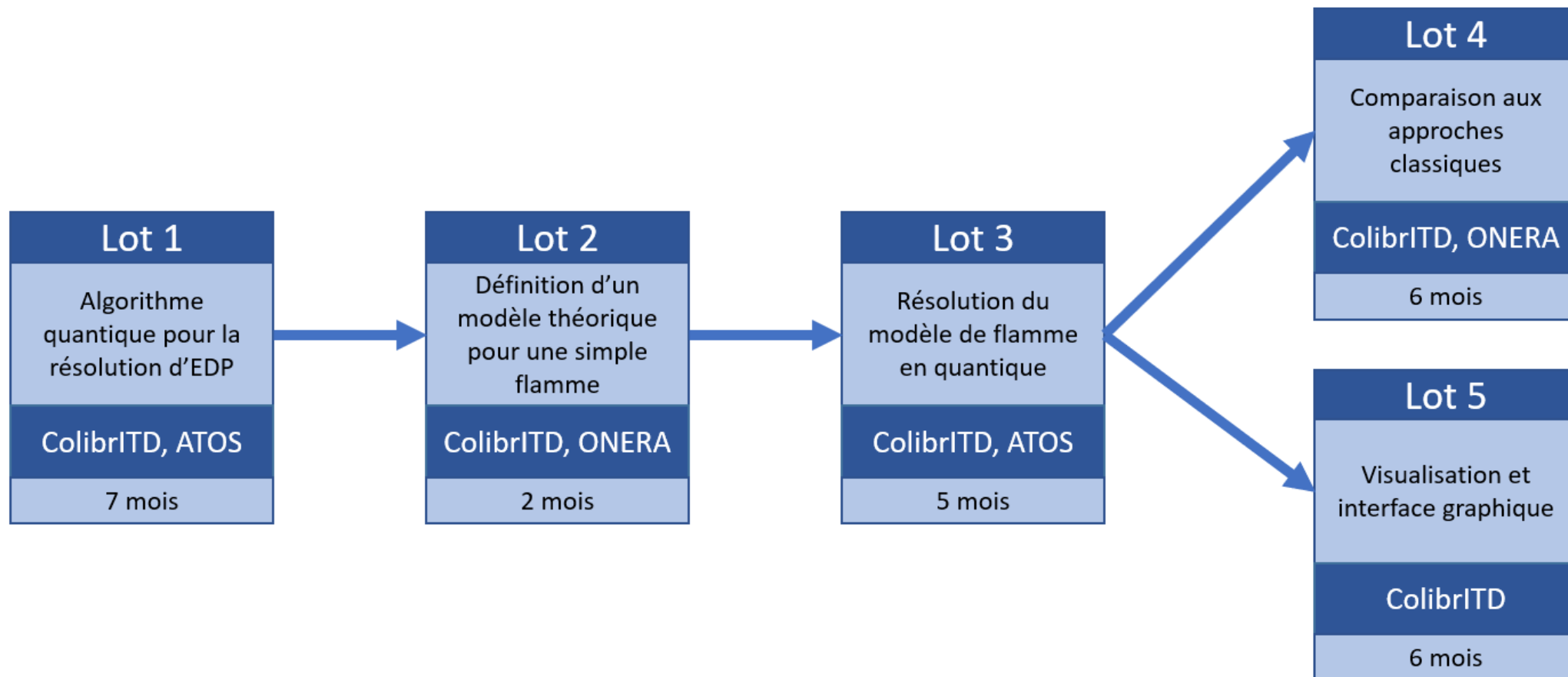
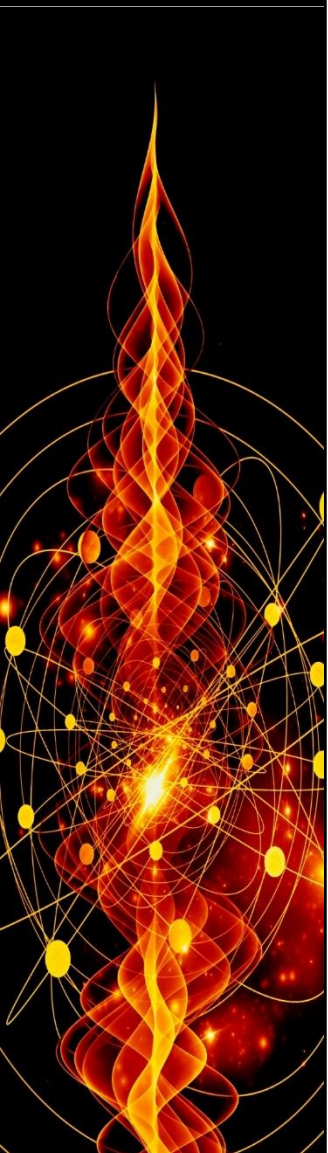



COLIBRITD

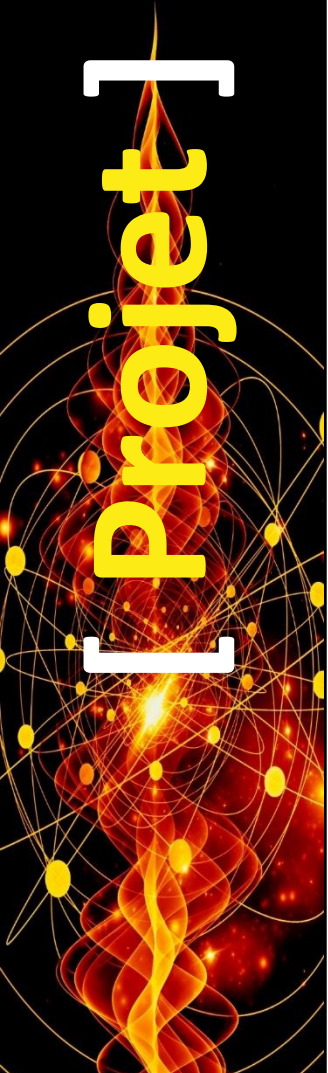

Thomas Rivera
PhD Research Project Manager
Orange



ParisRegionQCI Consortium

Thomas Rivera, ParisRegionQCI coordinator

Research Project Manager, ORANGE INNOVATION

ParisRegionQCI project description



Context of Quantum communications Project

- Following the publication of the report of the parliamentary mission on Quantum technologies January 9th, 2020 drafted by Paula Forteza, Jean-Paul Herteman and Iordanis Kerenidis,
- The report proposes 37 actions to build a French ecosystem for quantum technologies,
- The practical application in region IdF consists of two projects:
 - ✓ **Quantum computing:** development and exploitation of an infrastructure of quantum calculators such as system HPC,
 - ✓ **Quantum Communications:** development and exploitation of a fibre quantum network.

Quantum communications projects targets

- Development and the exploitation of an optical quantum network in region IdF,
- Development of systems of high TRL ($>$ TRL5) for quantum communication,
- Integration photonics of systems of quantum communication within an infrastructure of standard optical communication (dark fibre and enlightened fibre),
- Test the security of QKD protocols and material implementations of QKD systems,
- Demonstrator of quantum communication and technologies (notably QKD) on the infrastructure ParisRegionQCI.

Projet ParisRegionQCI (Quantum Communication Infrastructure)

✓ **Stackes :**

In the context of the fast development of the quantum technologies, provide to Ile-de-France area a fiber quantum network in order to get advantages of QKD technologies improving the robustness of the confidentiality of the data,

Federate companies, academic laboratories and public research establishments in the second quantum revolution.

✓ **Project's goal :**

Development and exploitation of a fiber network quantum in Ile-de-France area in the continuation of the project H2020 " OpenQKD ",

Implementation of a fibre infrastructure allowing the quantum distribution of keys, the integration of post-quantum and quantum algorithms in direct link with basic researches from academic laboratories.

Consortium & lead :

- ✓ 3 Majors : Thales SIX & Thales TRT, Nokia Bell Labs, Orange,
- ✓ 4 Start-ups : Quandela, CryptoNext, VeriQloud, Kets Quantum,
- ✓ 3 Academic labs : LIP6 (Sorbonne Université), Laboratoire Charles Fabry (IOGS), LTCI (Telecom Paris),
- ✓ Prime : Orange.

Budget :

- ✓ 2.25 M€.

Duration :

- ✓ 2 years + 6 months (2021-June 2023)

ParisRegionQCI first results & ongoing studies

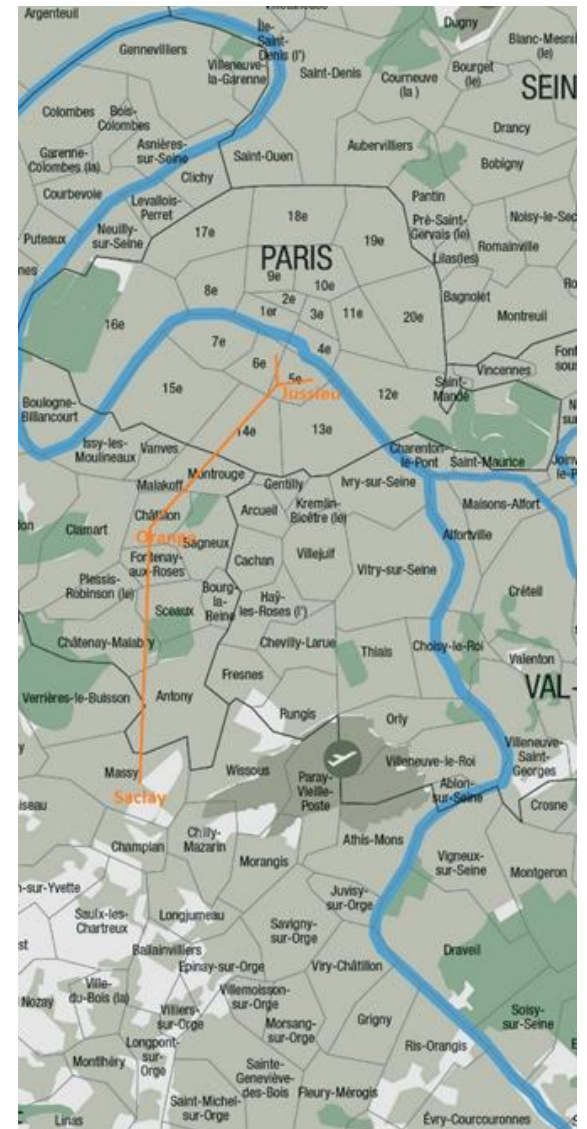

ParisRegionQCI Quantum backbone

- A quantum backbone has been established between the “Plateau de Saclay” (Telecom Paris) to Paris downtown (Jussieu) through Orange Innovation lab at Châtillon,
- ParisRegionQCI network uses already deployed fiber for classical optical communications,
- After a “customization” ParisRegionQCI network is compliant with quantum technologies and QKD technology has been validated between Jussieu (LIP6) & Orange quantum lab at Chatillon,
- First link characteristics between Telecom Paris and Orange Innovation are two 43 km fibers with 10.4 dB attenuation,
- Second link characteristics between Orange Innovation and Jussieu are two 14 km fibers with 3.8dB attenuation.

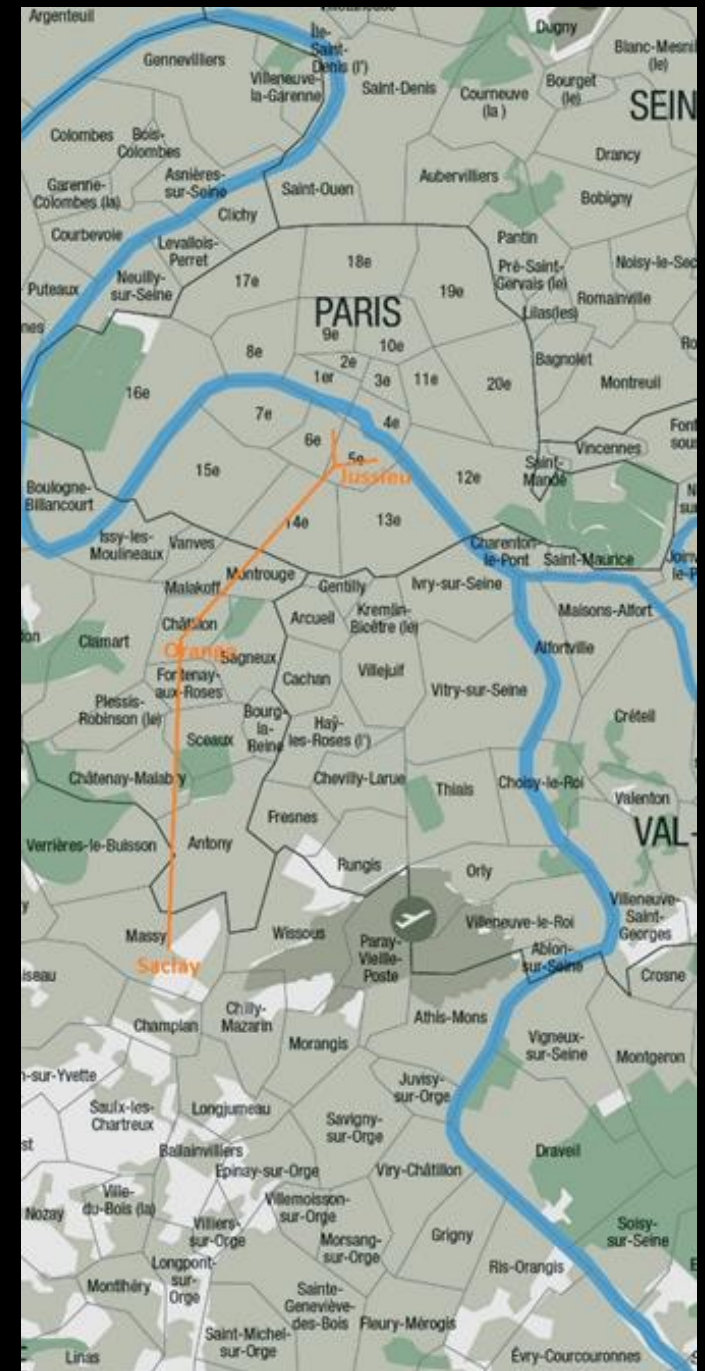

QKD Field trial between Orange at Chatillon to Sorbonne University (LIP6)

- A QKD field trial has been performed during 1 month between Jussieu to Chatillon using a Cerberis XGR from ID Quantique
- A specific network architecture has been deployed to be compliant with both security rules at Sorbonne University and at Orange Innovation
- Key Manager System has been identified as the critical layer for successful QKD deployment
- Quantum keys were exchanged at 2.33 Kbit/s key rate (291 Bytes/s) and a QBER at around 1.8 %

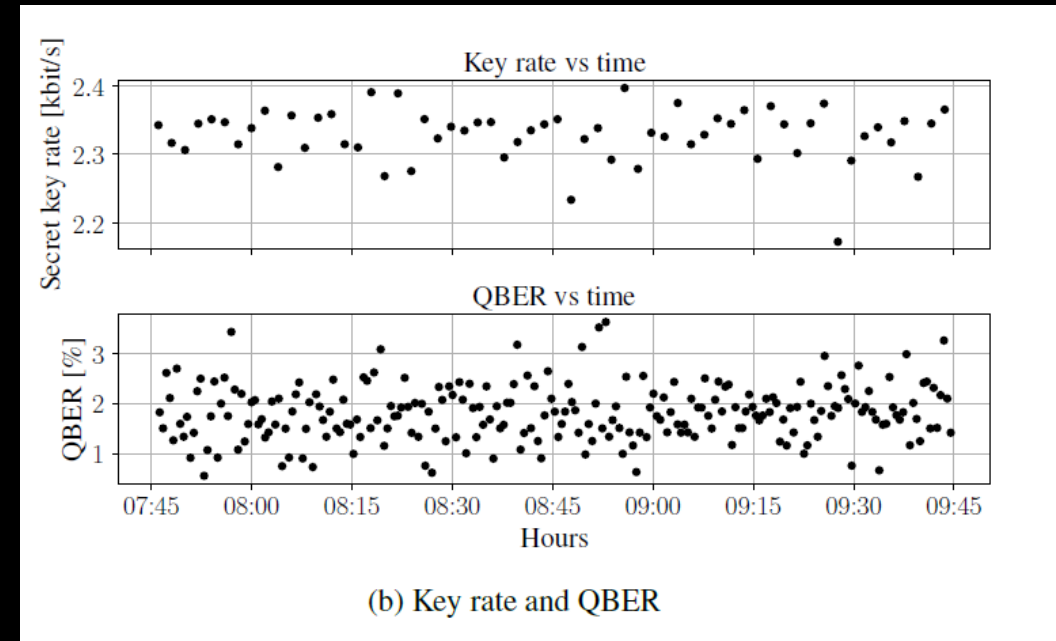

References: QCRYPT2022 August 2022 Taiwan:
ParisRegionQCI: A Parisian Quantum Network,
Yoann Piétri¹, Valentin Allaire², Pierre-Enguerrand Verdier², Matteo Schiavon¹, Jonathan Belhassen², Thomas Rivera², Eleni Diamanti¹
1, LIP6, CNRS, Sorbonne Université, F 75005 Paris, France
2, Orange Innovation, Chatillon, France

Experimental set-up between Jussieu and Chatillon

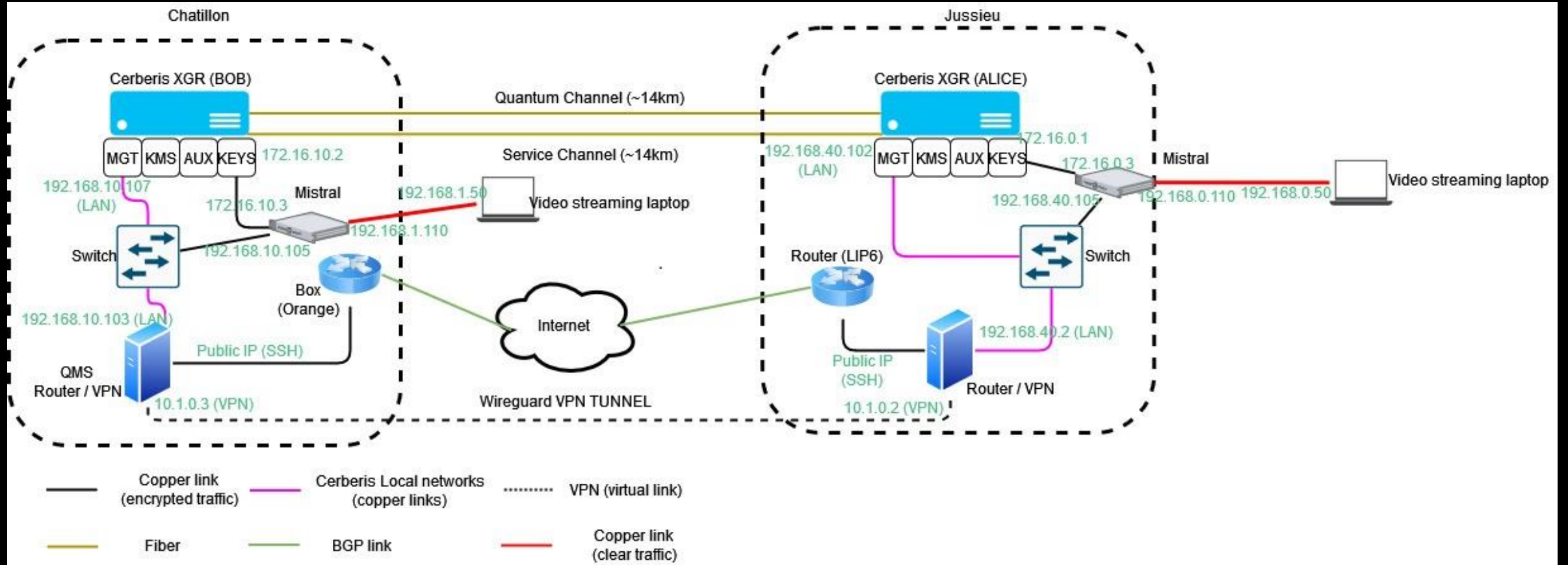

Quantum communication service between Orange at Chatillon up to Sorbonne University (LIP6)

- We have taken benefit to our quantum distribution to launch temporally a service using Quantum keys,
- Quantum encrypted streaming video as been performed between Orange at Chatillon to Sorbonne University (LIP6)
- Encryptors Mistral from Thales were used to ciphered (AES 256 b) a 4K video @ 6 Mbits/s,
- To our knowledge it's the first time in France that a QKD service was perform on the legacy Orange optical network using a commercial QKD system.

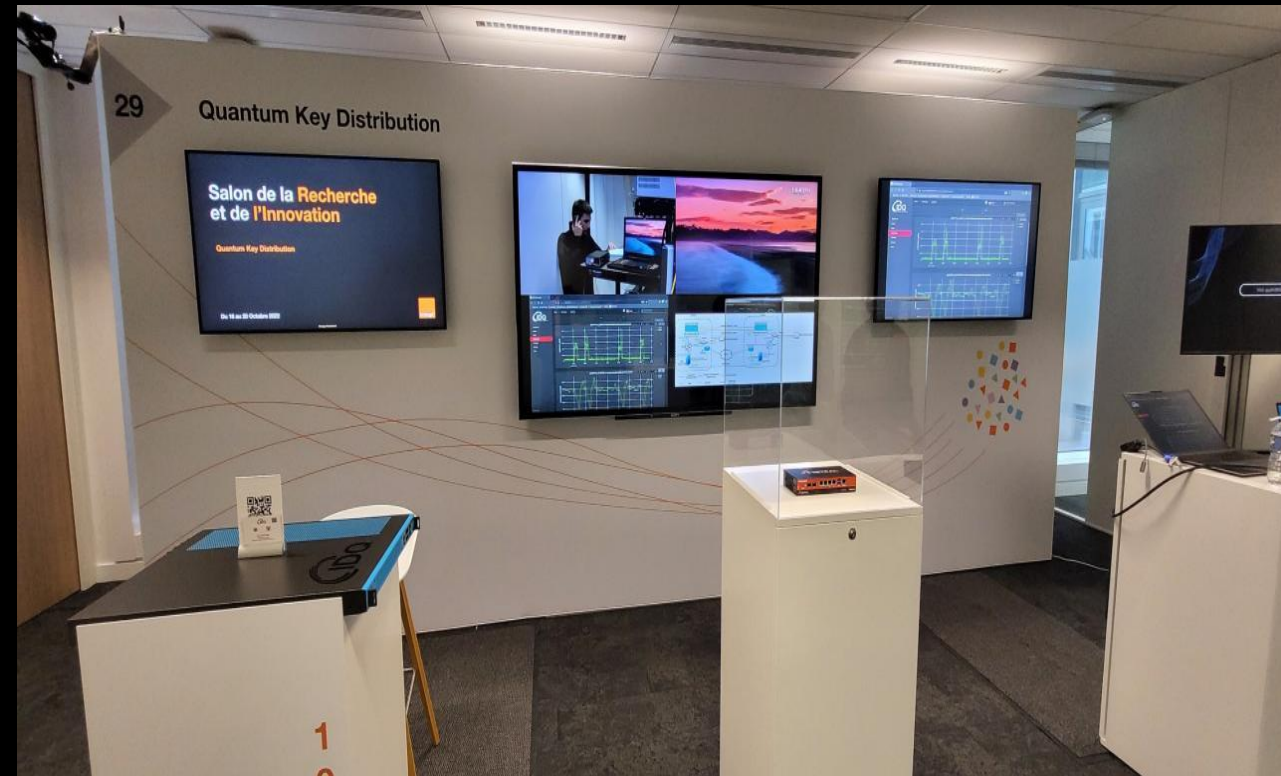

Quantum ciphered video streaming demo during Orange Research and Innovation Exhibition , 18-20 October Chatillon

THALES' work within ParisRegionQCI

System architecture

- **DONE** : Preliminary architecture for the testbed wrt available QKD technologies
- **ON GOING** : Assessment to a global system architecture targeting an operational QKD network on Paris Region Area

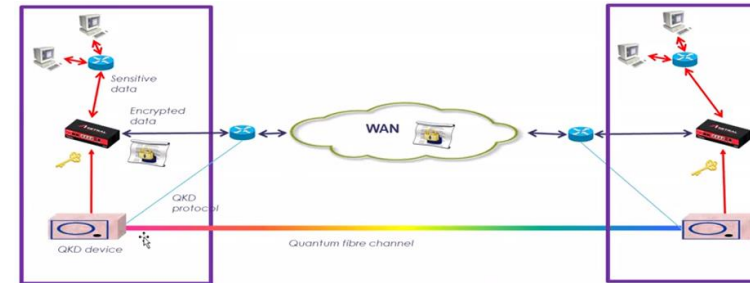

Thales encryptor interface compatible with QKD

- **DONE** : Encryptors interfaced with IDQuantique (& demo between Chatillon and LIP6)
- **ON GOING** : Development of an interface compatible with QKD device from a partner & associated demo on the testbed

CV-QKD prototype development

- **DONE** : Development, interfacing and characterization of CV-QKD opto-electronic block and post-processing block
- **ON GOING** : Deploy Alice and Bob on 2 nodes in Palaiseau (& demo potentially including Thales encryptors)

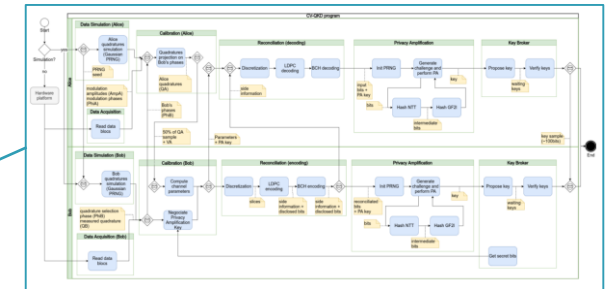

Commercial in confidence

THALES

Telecom Single Photon Source For Quantum Key Distribution

Quandela is developing an efficient turnkey telecom single photon source system for QKD applications

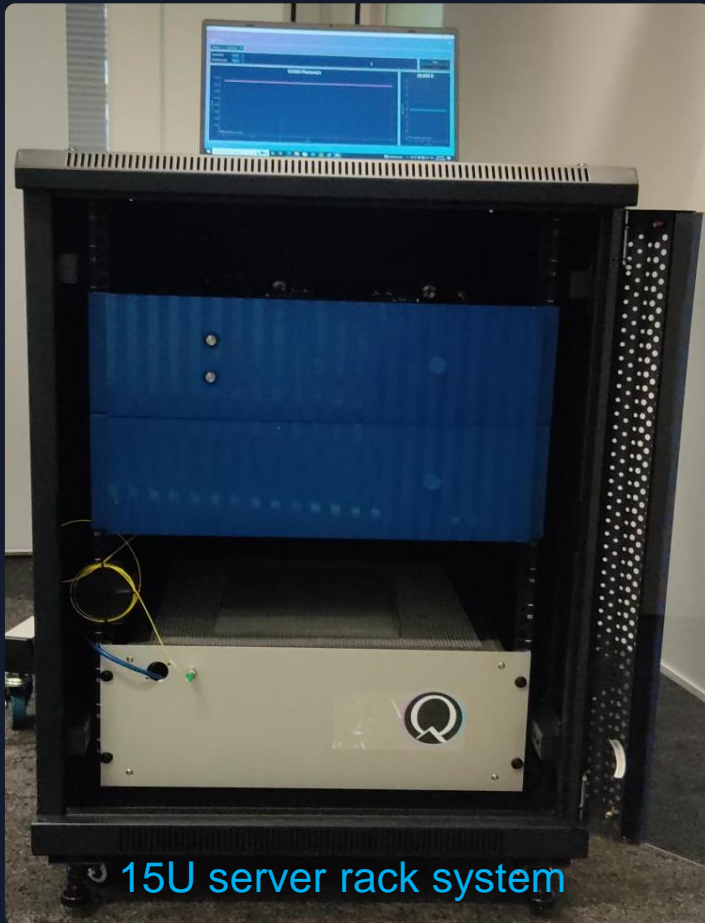

15U server rack system

Control Software

Wavelength conversion module

Single photon source control

780 nm Pigtailed Single Photon Source inside a 40K cryostat

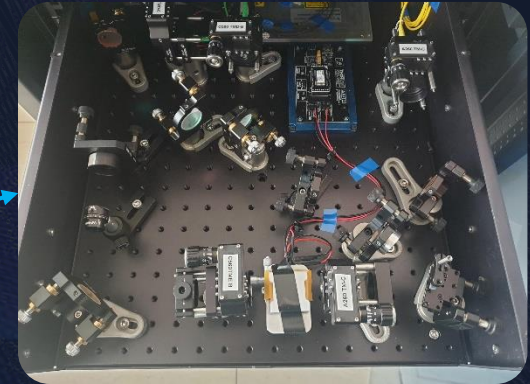

>50% conversion efficiency
>100 Signal to noise ratio

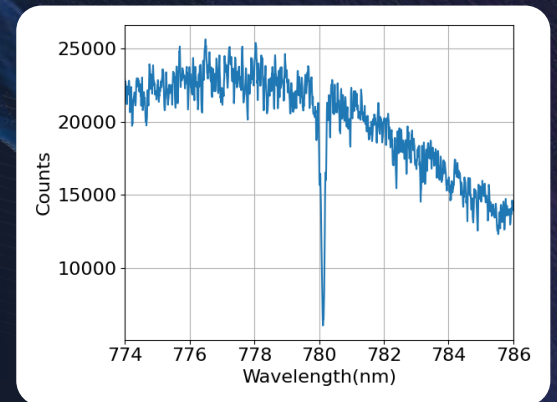

On-going development of high quality factor micropillars at 780 nm

Next generation high secret key rate CV-QKD systems leveraged by advanced coherent detection

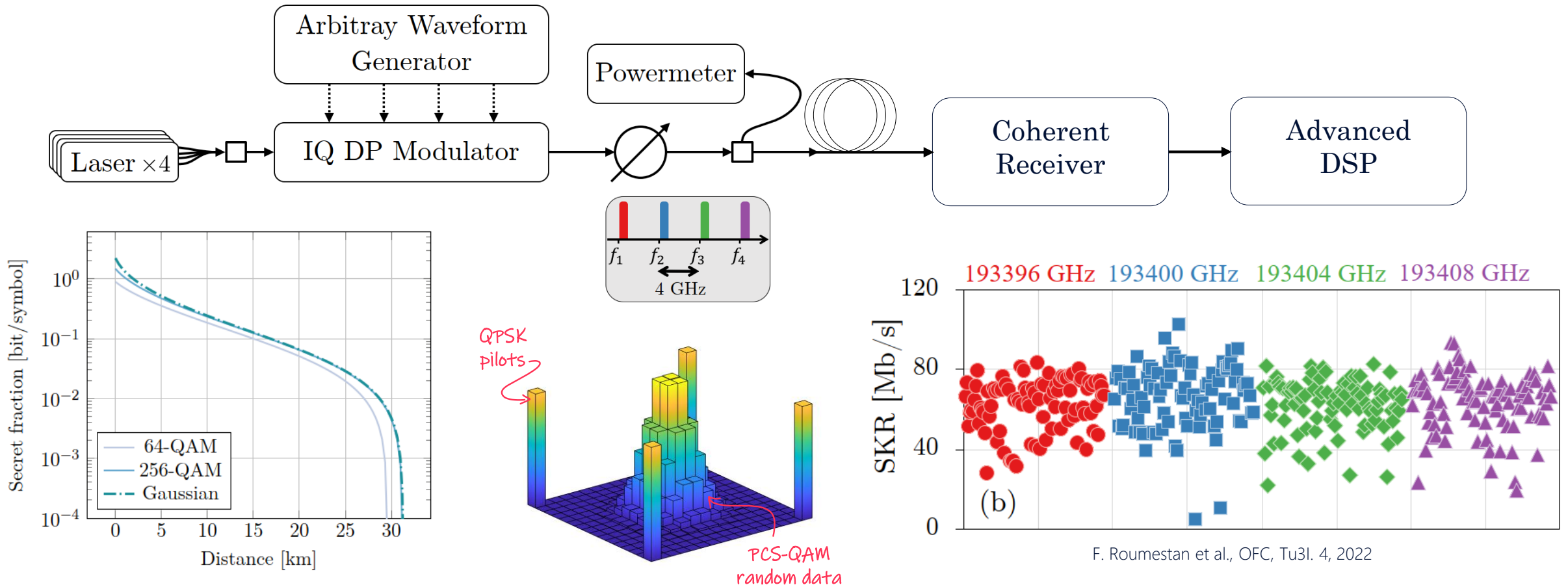

Aggregate 254.6 Mb/s over 13.5 km SSMF using PCS constellations and advanced coherent detection

Increase practical security of QKD with attack ratings

Prioritize “most dangerous” attacks

Method

Why?



Import Attack Rating from Common Criteria



SEC EVALUATION & CERTIFICATION



Apply to QKD to prioritize attacks

Identified Security Threat: Saturation attack on CV-QKD

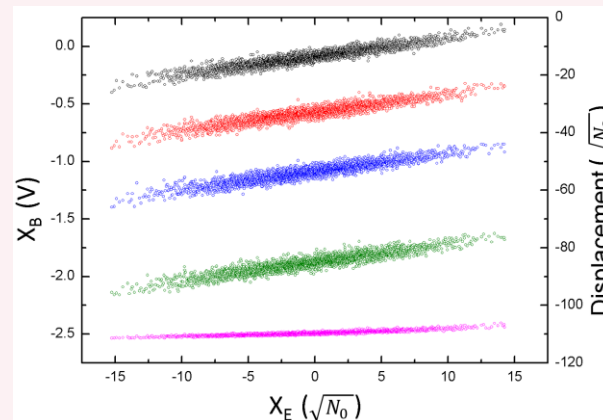
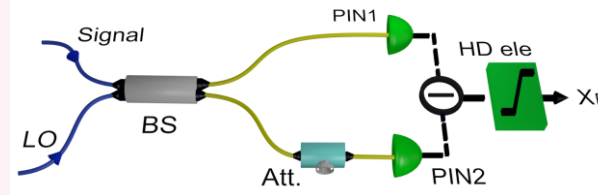

2 attack paths (coh / incoh)
Only coherent attack work

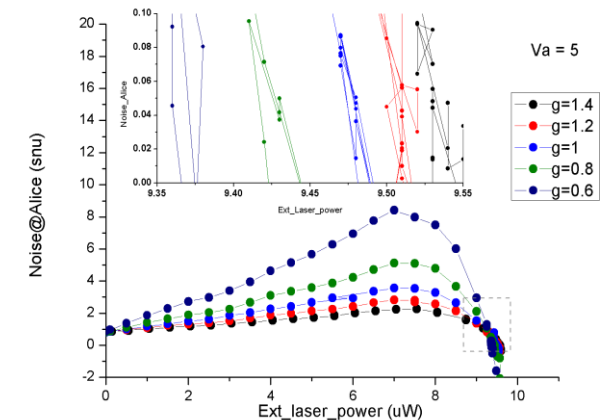

→ 2 different ratings
→ Incoh attacks more severe

✓ Attack ratings enable prioritization

Next steps: Standardization of Q Crypto Sec Evaluation:

- Protection Profile (with ETSI QKD ISG)
- Crypto standards

Essential steps for a European-scale market (EuroQCI)

- R. Kumar, F. Mazoncini, H. Qin, and R. Alléaume, Experimental vulnerability analysis of qkd based on attack ratings *Scientific Reports*, 22:9564, 2021.
- F. Mazoncini, RK, HQ and RA, Contributed Talk at Qcrypt 2021 <https://www.youtube.com/watch?v=RGV0GELP3H0>

ParisRegionQCI future & perspectives

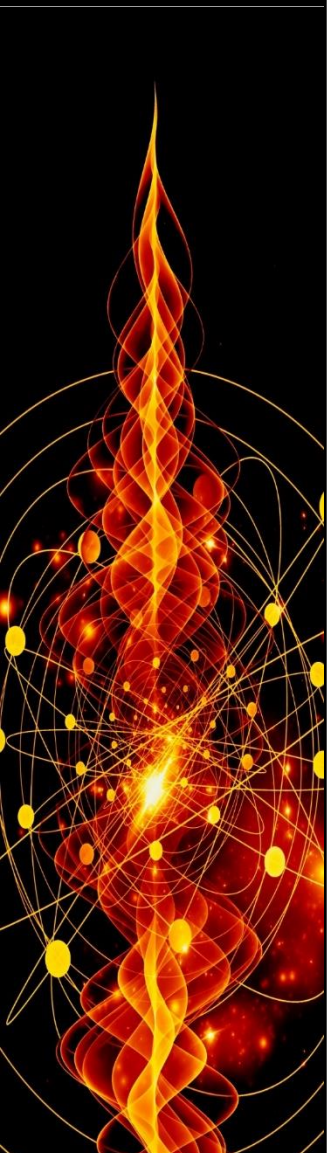
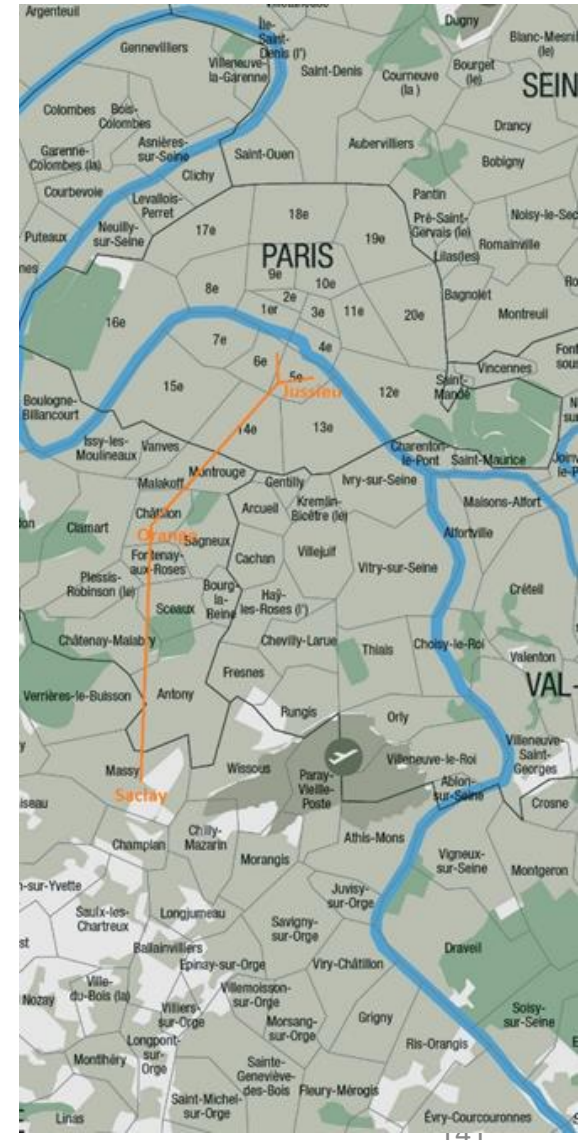

Stages and evolutions of the ParisRegionQCI network

- ✓ **Phase 1 (24 months + 6 months)** : Implementation of a first network based on existing fibers and implying 11 current partners, on which we shall validate a compatible engineering with the technologies QKD (CV and DV),
- ✓ **Phase 2** : A final network based on the engineering of the first network for typical users ministries, sensitive industries and the academic laboratories. This network will be much vaster than that of the first stage and will be connected to the Pan-european network QCI, by the use notably of segments,
- ✓ The final network will open to the other technologies quantum such as:
 - ✓ Shared quantum computing;
 - ✓ Quantum sensors networks ;
 - ✓ Quantum memories, entangled photon sources... (with DIM SIRTEQ academic consortium on quantum physics).

ParisRegionQCI Networks and future evolutions

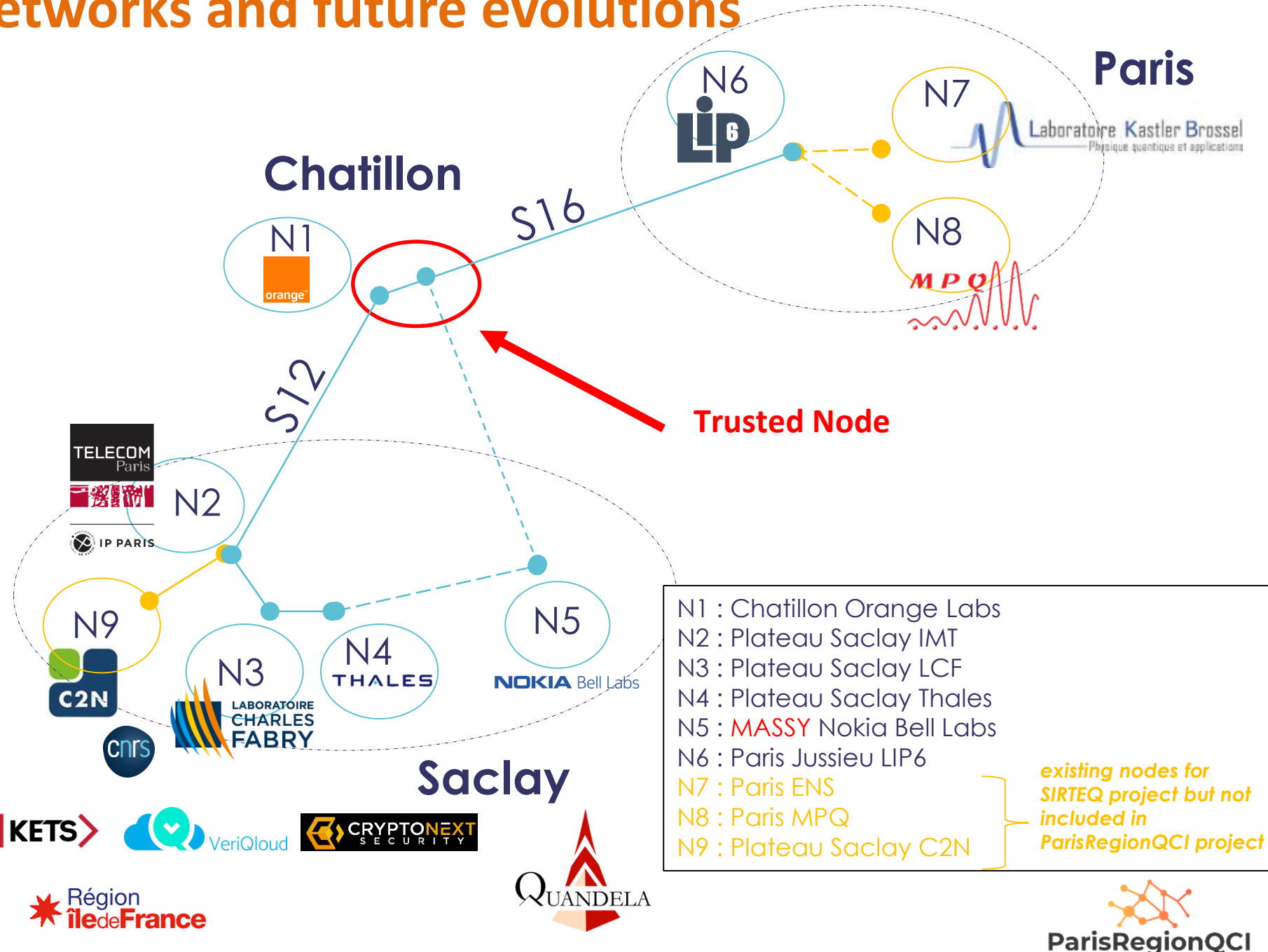

ParisRegionQCI toward FranceQCI

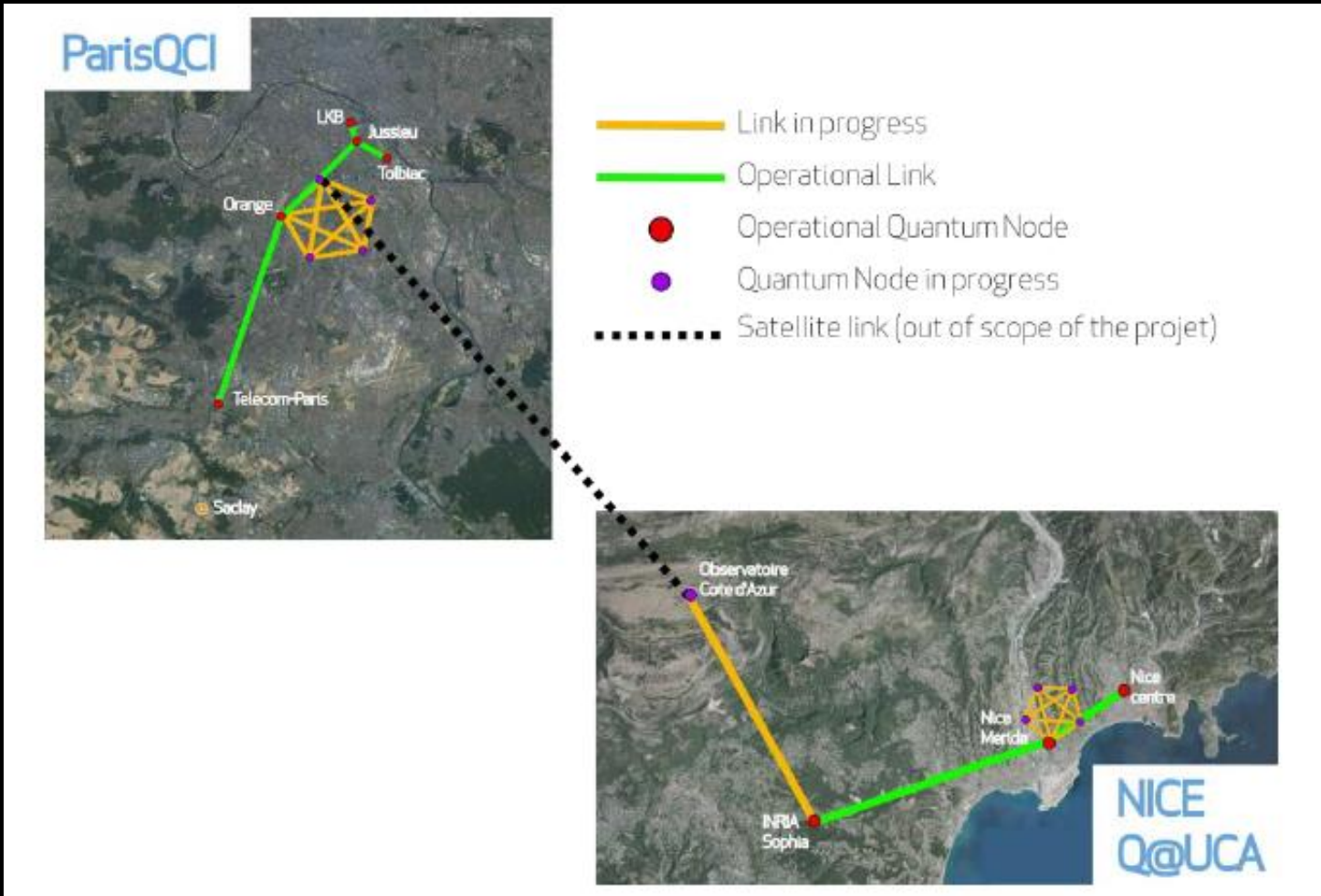

**Orange (OINIS)
is leader of FranceQCI consortium**

➤ **8 Partners from ParisRegionQCI**



➤ **Côte d'Azur University**



CÔTE D'AZUR



➤ **News partners:**



WeLinQ

Thanks





Neil Abroug

Head Of the French National Quantum Strategy
Secrétariat Général pour l'investissement

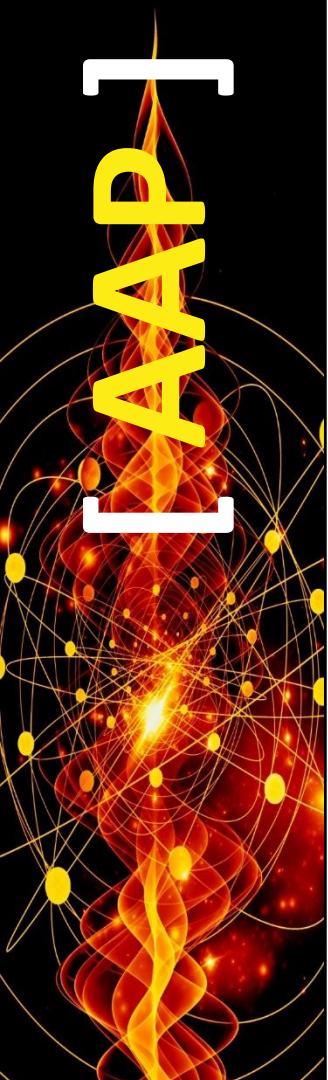

Emmanuelle Vergnaud
Directrice des opérations
Teratec



Esther Slamitz
Coordinatrice Hub « Digital Engineering »
Systematic



Thierry Louvet
Responsable Europe et International
Systematic



TERATEC

- ❖ Mis en place en 2020 par la Région Ile-de-France pour :
 - ❖ Renforcer le leadership de la Région dans l'acquisition de l'avantage quantique
 - ❖ Favoriser l'appropriation et le développement du calcul quantique par les acteurs économiques, industriels et startups

- ❖ Principe : Une startup travaille sur un cas d'usage fourni par un industriel
- ❖ Durée 2 ans
- ❖ Financement de la startup à hauteur de 50% des frais soit jusqu'à un montant maximal de 300k€ pour un montant total de 600k€
- ❖ Montée en compétence des industriels et meilleure compréhension de leurs enjeux par les startups

9 projets accompagnés - 1,9M€ de soutien régional pour un investissement total de 4M€



[PAQ]

[PAQ]

2020

AQMUSE

Avantage Quantique pour le multi sourcing Energie



2020

AQUARE

Avantage QUANTique pour la Résolution de problèmes complexes pour l'Énergie



2020

AQMED

Avantage Quantique pour la Conception de MEDicaments

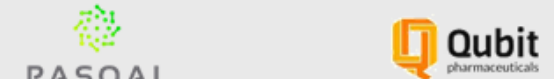

2021

OCH2Q

Optimisation de la Conversion de l'Hydrogène par le calcul Quantique



2021

AQUAPS

Avantage QUANTique pour la résolution de problèmes de Planning & Scheduling

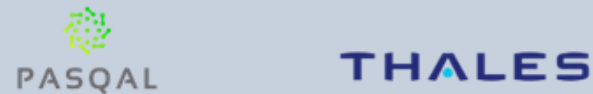

2022

AQCMA

Avantage Quantique pour la Conception de Moteurs dans l'Aéronautique



2022

AQUAEDP

Avantage Quantique pour la résolution d'EDP



2022

QMLCat

Quantum Machine Learning using Cat Qubits



2022

AQGeTAD

Avantage Quantique pour la Gestion du trafic aérien de drones



Opérateur public créé en 2007

Objectifs

- Mettre en œuvre la stratégie nationale d'équipement en moyens de calcul intensif en lien avec les 3 centres nationaux (CEA/TGCC, CNRS/IDRIS, France Universités/CINES)
- Soutenir la réalisation d'un écosystème du calcul intensif à l'échelle nationale et européenne dans le cadre de PRACE et EuroHPC
- Promouvoir la simulation numérique et le calcul intensif auprès de la recherche académique et des industriels
- mais aussi participer à l'initiative nationale de calcul quantique hybride HQI

Association Le Lab Quantique

Missions

- Promouvoir les technologies quantiques en France et à l'international
- Réunir, renforcer et représenter les membres de l'écosystème quantique français
- Organiser des Hackathons, meetups, conférences, afin de connecter l'industrie, les startups et les talents
- Accompagner les organisations quantiques dans leur recherche de capitaux, partenaires et experts

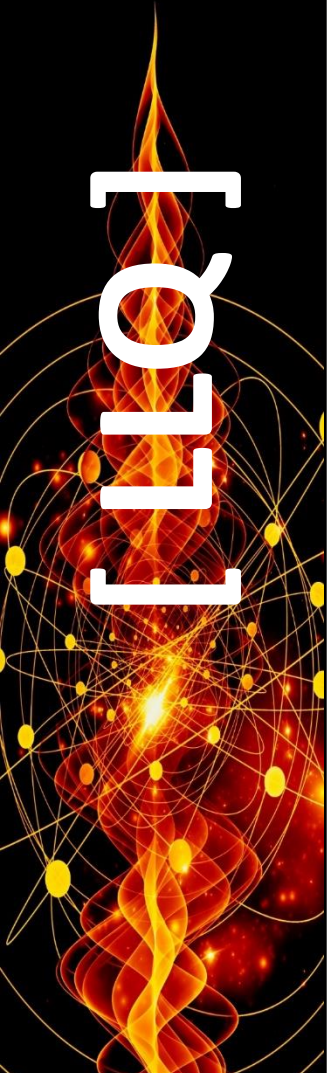

LES PARTENAIRES

Initiative lancée dès 2018 par Teratec et ses partenaires industriels et académiques

Objectifs

- Créer un écosystème dynamique fédérant industriels utilisateurs, offreurs de technologie et centres de recherche, pour monter rapidement en compétences et développer le savoir-faire dans le domaine du calcul quantique
- Améliorer la compréhension des principes fondamentaux du calcul quantique et des modèles de programmation correspondants

Prochain séminaire le 11 janvier Organisé par EDF avec le soutien de TQCI

3 sessions - Hybridation QPU / CPU-GPU

→ Hybridations matérielles : état de l'art / prochains verrous / prochains enjeux

Quandela, Pasqal, HQI, NVIDIA

→ Développement de code, compilation et runtime

AWS, ATOS, IBM, Los Alamos

→ Hybridation entre les QPUs

Welinq

2 keynotes

→ Consommation énergétique et hybridation (QEI)

→ L'impact de la réduction du temps de latence sur l'algorithmique (MS)



SYSTEMATIC

Time Line : Processus de labellisation

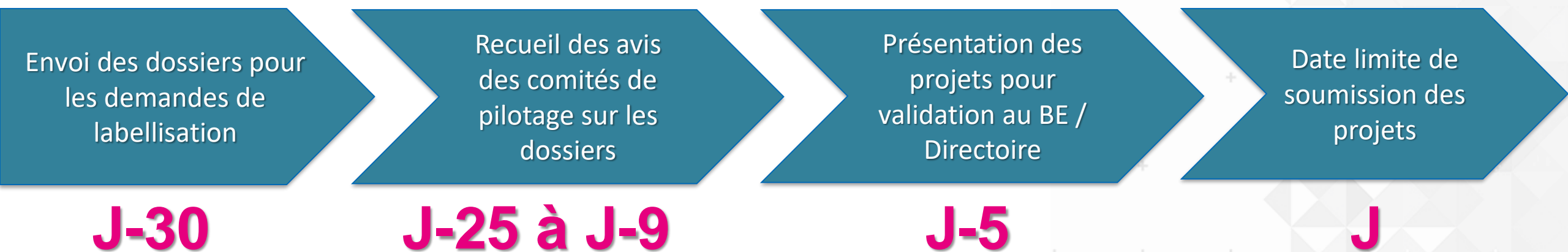

Je suis porteur d'un projet d'innovation, mon projet s'inscrit dans l'une des thématiques des hubs et enjeux du pôle et répond à leurs feuilles de route :



Comment je labellise mon projet ?

Les 6 étapes clés de la labellisation

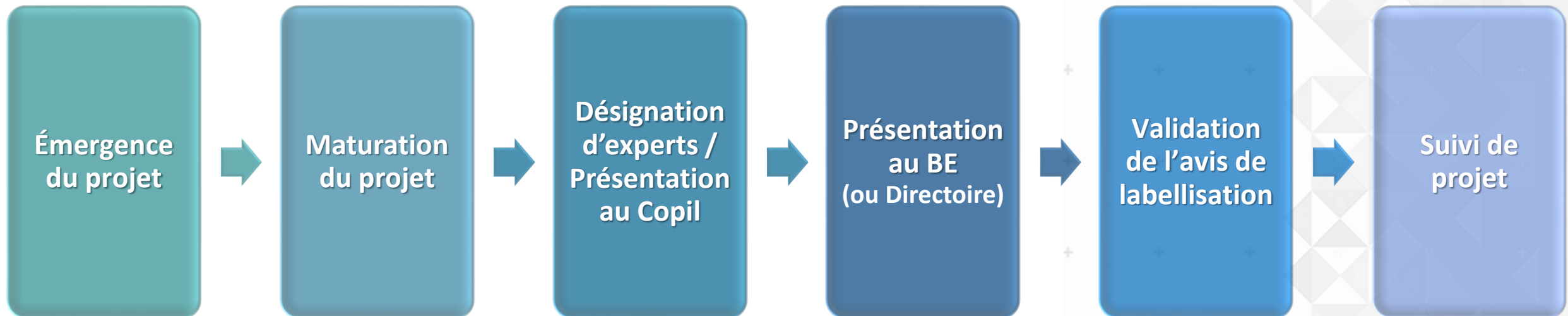

Systematic vous accompagne dans vos projets de R&D

Nous sommes là pour vous accompagner,
vous prodiguer conseils et recommandations.

Soumettez vos projets **au moins un mois** avant la date de clôture à

depot.projet@systematic-paris-region.org

Renseignements : innovation@systematic-paris-region.org

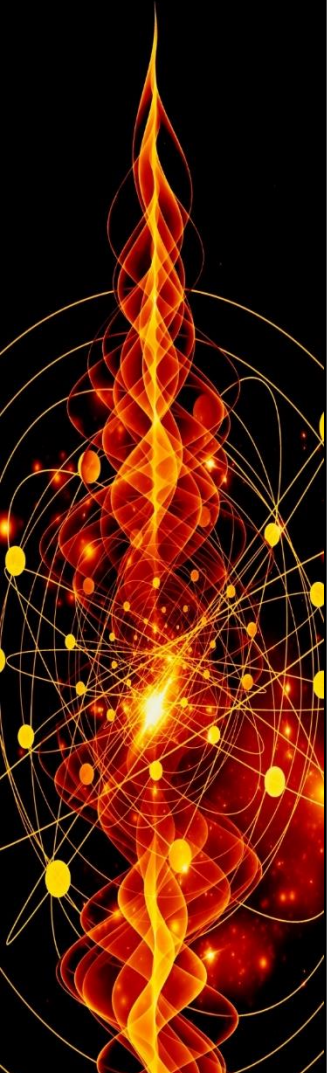



PROFIL DES PROJETS ATTENDUS

De 3 à 5 partenaires dont au moins :

- 1 PME/ETI
- 1 Entreprise PME ETI ou GG
- 1 Académique

Durée de 24 à 60 mois

Budget de 1 à 4 M€

Les partenaires d'un même projet pourront :

- Soit tous appartenir au même territoire régional : « projets collaboratifs intrarégionaux »
- Soit être issus de territoires régionaux différents : « projets collaboratifs interrégionaux »

Calendrier prévisionnel prochaine relève le 26 avril 2023

IMPULSE 2023

i-Démo régionalisé - Faites émerger vos projets collaboratifs innovants pour relever les grands défis de demain.

Date : Le 9 février 2023

Horaires : 09:00 | 14:30

Lieu : Conseil Régional d'Île-de-France, 2 Rue Simone Veil, 93400 Saint-Ouen

Au programme : temps de **pitch, d'ateliers et de matchmaking** pour favoriser les rencontres qui permettent l'émergence de nouveaux projets. Après un temps de présentation de l'appel et des enjeux clés à adresser, les équipes des 5 pôles franciliens seront à vos côtés pour initier les bonnes rencontres et connecter vos idées et projets aux bons partenaires.

Une plateforme de matchmaking est également proposée pour vous permettre de planifier vos rendez-vous lors de l'événement.



Contacts

- **Plus d'infos :**
- <http://leaderpia.iledefrance.fr/>

- **Vous souhaitez bénéficier de l'accompagnement du pôle ?**
- Contactez le coordinateur de votre hub ou enjeu, ou contactez johan.dhose@systematic-paris-region.org

Structure Horizon Europe – 2021 - 2027

Budget global : 95,5 Mrd €



[Horizon Europe]

N°	Topic	Titre	Type	Dates	Budget M€	Nb de projets attendus
1	HORIZON-CL4-2023-DIGITAL-EMERGING-01-40	Quantum Photonic Integrated Circuit technologies	RIA*	1 Dec 2022 29 Mar 2023	12	2
2	HORIZON-CL4-2023-DIGITAL-EMERGING-01-41	Investing in alternative quantum computation and simulation platform technologies	RIA	1 Dec 2022 29 Mar 2023	20	2
3	HORIZON-CL4-2023-DIGITAL-EMERGING-01-43	Framework Partnership Agreement for developing large-scale quantum Computing platform technologies (FPA)	FPA*	1 Dec 2022 29 Mar 2023		
4	HORIZON-CL4-2023-DIGITAL-EMERGING-01-50	Next generation quantum sensing and metrology technologies	RIA	1 Dec 2022 29 Mar 2023	10	3

[Horizon Europe]

N°	Topic	Titre	Type	Dates	Budget M€	Nb de projets attendus
5	HORIZON-CL4-2024-DIGITAL-EMERGING-01-42	Stimulating transnational research and development of next generation quantum technologies, including basic theories and components (Cascading grant with FSTP)	RIA	15 Nov 2023 19 Mar 2024	15	1
6	HORIZON-CL4-2024-DIGITAL-EMERGING-01-45	Quantum sensing and metrology for market uptake	IA*	15 Nov 2023 19 Mar 2024	15	3
7	HORIZON-CL4-2023-SPACE-01-62	Quantum Communication Technologies for space systems	RIA	22 Dec 2022 28 Mar 2023	5	2
8	HORIZON-CL4-2023-SPACE-01-63	Quantum Space Gravimetry Phase-A Study	RIA	22 Dec 2022 28 Mar 2023	3	2

N°	Topic	Titre	Type	Dates	Budget M€	Nb de projets attendus
9	HORIZON-CL4-2024-SPACE-01-64	Quantum Space Gravimetry Phase-B study & Technology Maturation	RIA	21 Nov 2023 20 Feb 2024	14,2	1

*FPA = Framework Partnership Agreement

*IA = Innovation Action

*RIA = Research and Innovation Action

La différence entre IA et RIA est principalement le niveau de TRL auquel l'appel est destiné. Un RIA est censé avoir un résultat avec un TRL de 2 à 6, tandis qu'un IA est destiné à des TRL plus élevés entre 6 et 8.

Le taux de financement des projets RIA est de 100 % des coûts éligibles pour tous les types d'organisation, tandis que le taux pour les IA peut être inférieur en fonction de leur statut juridique. Dans ce cas, le taux est de 70 % pour les entités à but lucratif et de 100 % pour celles à but non lucratif.

Un partenariat-cadre (FPA) est un mécanisme de coopération à long terme entre la Commission et les bénéficiaires de subventions. Le FPA précise les objectifs communs, la nature des actions prévues de manière ponctuelle ou dans le cadre d'un programme de travail annuel approuvé, la procédure d'octroi de subventions spécifiques, ainsi que les droits et obligations généraux de chaque partie au titre des conventions ou décisions spécifiques.

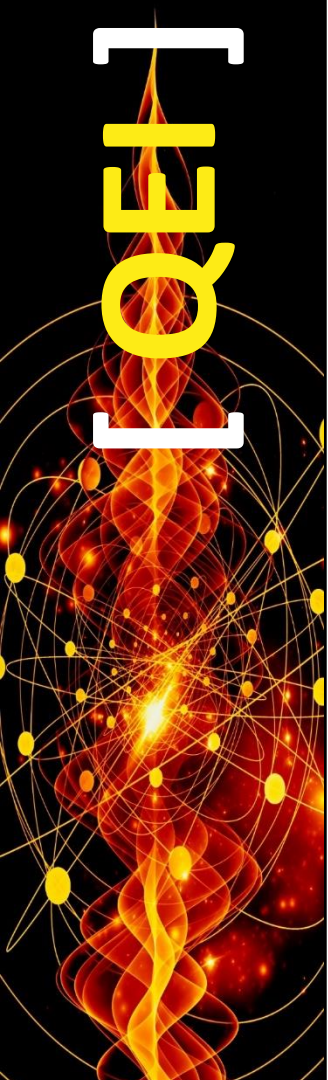

Olivier Ezratty

#QEI

the quantum energy initiative

Alexia Auffèves, **Olivier Ezratty**, Janine Splettstoesser, Robert Whitney
Singapore, Paris, Stockholm, Grenoble, December 8th, 2022

how about quantum technologies?

RESEARCH-ARTICLE



Energy Cost of Quantum Circuit Optimisation: Predicting That Optimising Shor's Algorithm Circuit Uses 1 GWh

Authors: [Alexandru Paler](#), [Robert Basmadjian](#) [Authors Info & Claims](#)

ACM Transactions on Quantum Computing, Volume 3, Issue 1 • March 2022 • Article No.: 3, pp

<https://dl.acm.org/doi/10.1145/3490172>

← energy hog?

or energy saver?

Is quantum computing green? An estimate for an energy-efficiency quantum advantage

Daniel Jaschke^{1,2,3} and Simone Montangero^{1,2,3}

¹*Institute for Complex Quantum Systems, Ulm University, Albert-Einstein-Allee 11, 89069 Ulm, Germany*

²*Dipartimento di Fisica e Astronomia "G. Galilei" & Padua Quantum Technologies
Research Center, Università degli Studi di Padova, Italy I-35131, Padova, Italy*

³*INFN, Sezione di Padova, via Marzolo 8, I-35131, Padova, Italy*

(Dated: May 25, 2022)

<https://arxiv.org/abs/2205.12092>

Quantum Energy Initiative vision paper



PRX QUANTUM
a Physical Review journal

Highlights Recent Accepted Authors Referees Search About Scope Staff

Perspective Open Access

Quantum Technologies Need a Quantum Energy Initiative

Alexia Auffèves
PRX Quantum **3**, 020101 – Published 1 June 2022

Article References No Citing Articles PDF HTML Export Citation

ABSTRACT

Quantum technologies are currently the object of high expectations from governments and private companies, as they hold the promise to shape safer and faster ways to extract, exchange, and treat information. However, despite its major potential impact for industry and society, the question of their energetic footprint has remained in a blind spot of current deployment strategies. In this Perspective, I argue that quantum technologies must urgently plan for the creation and structuration of a transverse quantum energy initiative, connecting quantum thermodynamics, quantum information science, quantum physics, and engineering. Such an initiative is the only path towards energy-efficient, sustainable quantum technologies, and to possibly bring out an energetic quantum advantage.

<https://journals.aps.org/prxquantum/abstract/10.1103/PRXQuantum.3.020101>

#QEI

the quantum energy initiative

goals & missions



create a **worldwide community** working on quantum technologies energetics associating fundamental research and industry vendors.

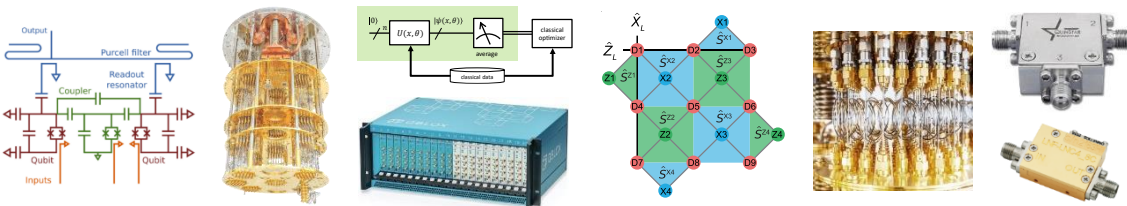

create a new **transversal line of research** and **collaborative projects**.

(a) Metric-Noise-Resource (MNR) methodology for the full-stack of a quantum computer

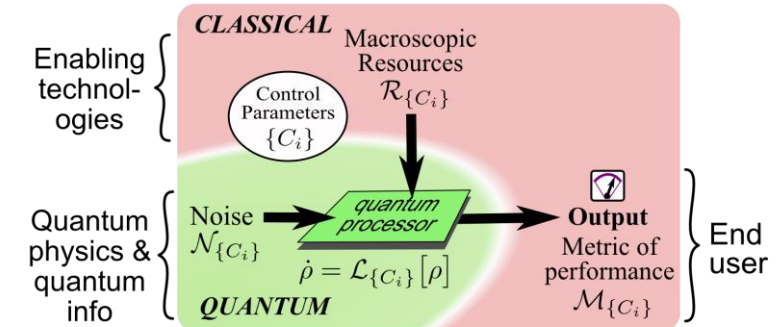

propose **optimization methodologies, frameworks** and **benchmarks** for quantum technologies, enabling technologies and software engineering

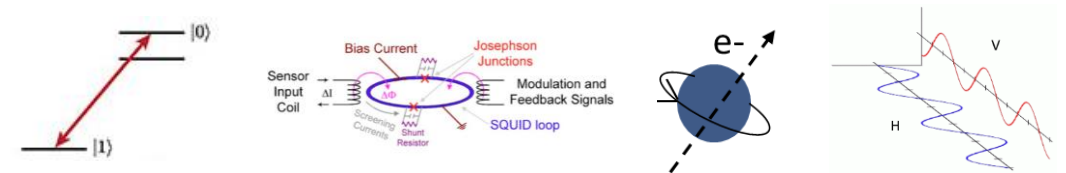

cover **all qubit types, programming paradigms,** and other quantum technologies (communications, sensing)

Optimizing resource efficiencies for scalable full-stack quantum computers

Marco Fellous-Asiani,^{1,2,*} Jing Hao Chai,^{2,3} Yvain Thonnart,⁴ Hui Khoon Ng,^{5,3,6,†} Robert S. Whitney,^{7,‡} and Alexia Auffèves^{2,6,§}

¹*Centre for Quantum Optical Technologies, Centre of New Technologies, University of Warsaw, Banacha 2c, 02-097 Warsaw, Poland*

²*Université Grenoble Alpes, CNRS, Grenoble INP, Institut Néel, 38000 Grenoble, France*

³*Centre for Quantum Technologies, National University of Singapore, Singapore*

⁴*Université Grenoble Alpes, CEA-LIST, F-38000 Grenoble, France*

⁵*Yale-NUS College, Singapore*

⁶*MajuLab, International Joint Research Unit UMI 3654,*

CNRS, Université Côte d'Azur, Sorbonne Université,

National University of Singapore, Nanyang Technological University, Singapore

⁷*Université Grenoble Alpes, CNRS, LPMMC, 38000 Grenoble, France.*

<https://arxiv.org/abs/2209.05469>



early findings applying the MNR methodology in a particular example

1. **energy advantage** may show up before **computing advantage**.
2. x10 qubit fidelities => **x100 energy savings**.
3. **quantum error correction codes** impact energetic footprint.
4. in FTQC, **control electronics** consumes more energy than cryogeny.
5. significant progress needed in control electronics (room temperature, cryo-electronics, cabling, multiplexing).

it's only a beginning, with many outstanding challenges in all quantum technologies

#QEI so far

the quantum energy initiative

QEI position paper, incl. the MNR framework proposal
June 2022



first MNR implementation
September 2022

Optimizing resource efficiencies for scalable full-stack quantum computers

Marco Fellous-Asiani,^{1,2,*} Jing Hao Chai,^{2,3} Yvain Thonnart,⁴ Hui Khoon Ng,^{5,3,6,†} Robert S. Whitney,^{7,3} and Alexia Auffèves^{2,6,8}



QEI Poll & Manifesto
August 2022



QEI first partners
November 2022

Perspective

Open Access

Quantum Technologies Need a Quantum Energy Initiative

Alexia Auffèves

PRX Quantum **3**, 020101 – Published 1 June 2022



WELCOME MANIFESTO JOIN US FAQ CONTACT

Latest Signatures			
224	Alexis Askitopoulos	Greece	qubitech.eu CSO, co-founder
223	Finn Schmolke	Germany	Universität Stuttgart PhD student
222	Matteo Carrega	Italy	CNR-SPIN Researcher
221	Benjamin Heinrich	Germany	Nature Nanotechnology Senior editor
220	Julie Virly	France	La Poste IT Market Intelligence Manager
219	Alain Dessertaine	France	La Poste Expertise Data-Science
218	Samuel Lara-Avila	Sweden	Chalmers University of Technology Associate Professor
217	Jose Luis Hevia Oliver	Spain	aQuantum CTO

231 signatures from 34 countries



#QEI first partners

the quantum energy initiative

research



National University of Singapore



industry



PASQAL

ALICE & BOB

QUANDELA

Atos



HPC service providers



industry associations



proposed structure and overview

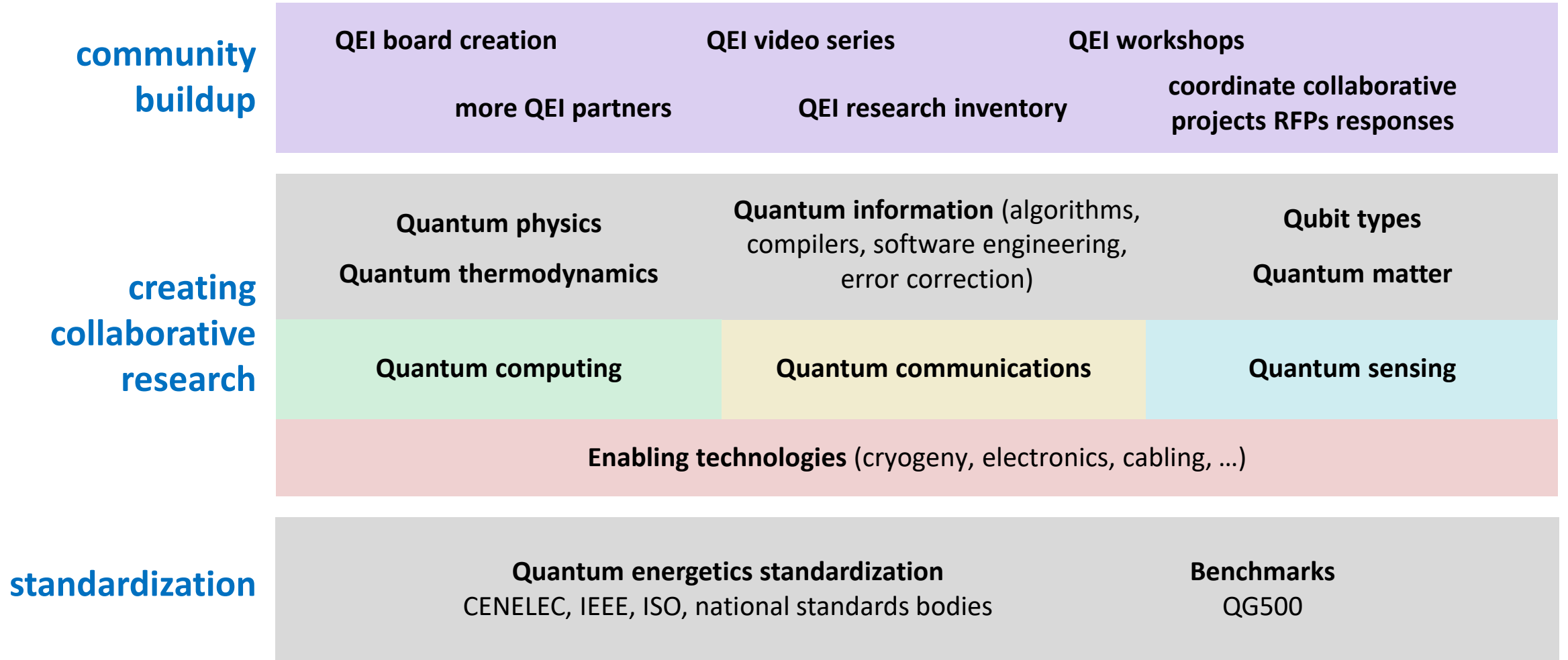



contacts

contact@quantum-energy-initiative.org



Olivier Ezratty

Quantum Technologies
Consultant and Author
olivier@oezratty.net



Alexia Auffèves

CNRS Research Director
MajuLab, Singapore
alexia.auffeves@neel.cnrs.fr



Janine Splettstoesser

Professor
Chalmers University
janines@chalmers.se

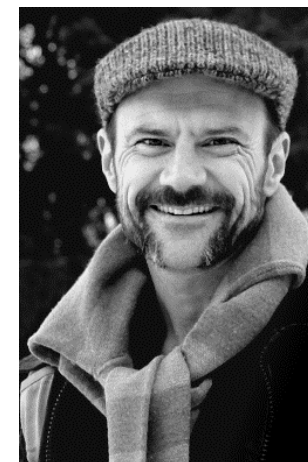

Robert Whitney

Researcher
CNRS LPMMC Grenoble
robert.whitney@lpmmc.cnrs.fr

« Présentation compétences »

- **Zurich Instruments** : Jelena Trbovic
- **Maison de la Simulation** : Victor Alessandrini
- **CS Group** : Matthijs Van Waveren
- **Icon Photonics** : Jean-Luc Polleux
- **SEDI-ATI** : Sofiane Bahbah
- **Thales** : Frédéric Barbaresco
- **Université de Clermont-Ferrand** : Philippe Lacomme
- **Viqthor** : Guillaume De Giovanni

[3 minutes
pour convaincre]

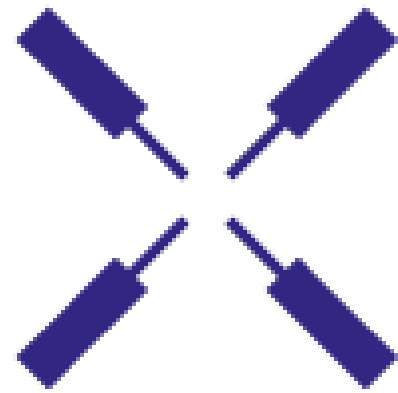

Zurich
Instruments

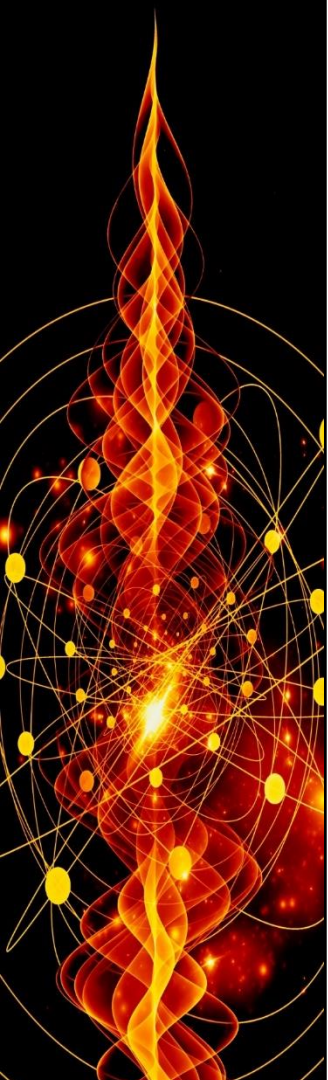

Jelena Trbovic PhD, Quantum Technologies Business Development

CONTROL ELECTRONICS COLLABORATIONS ZURICH INSTRUMENTS

FROM IDEA TO REALITY



Qubits

Superconducting
Trapped Ions
Cold Atoms
Photons
Spin (Si, C, SiGe...)
NV Centers
Topological
Andreev

Control Electronics

Frequency Range
High resolution
High Dynamic Range
Low amplitude noise
Low phase noise
Low latency
Scalable
Affordable

Software

Pulse level control
Scalable
Compatible
Fast compiling
Open
Easy to use
Application Adaptive
App SW ready

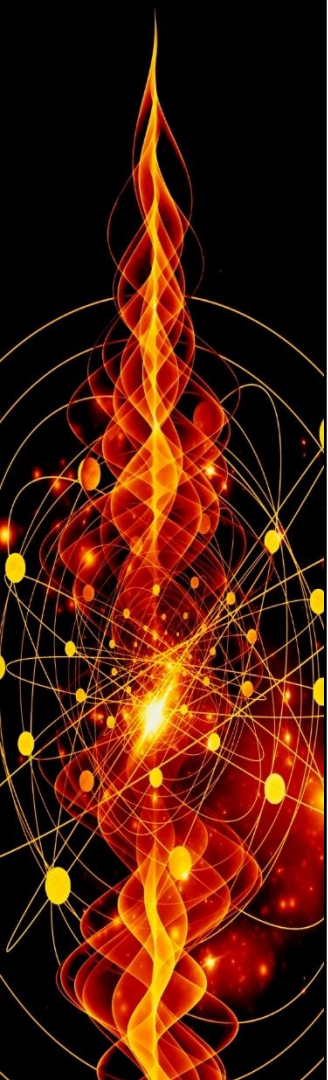

< QCCS | Quantum Computing Control System >

Applications and Algorithms

Quantum Programming

Quantum Machine Language

Classical System Control
Software and Hardware

Quantum Device

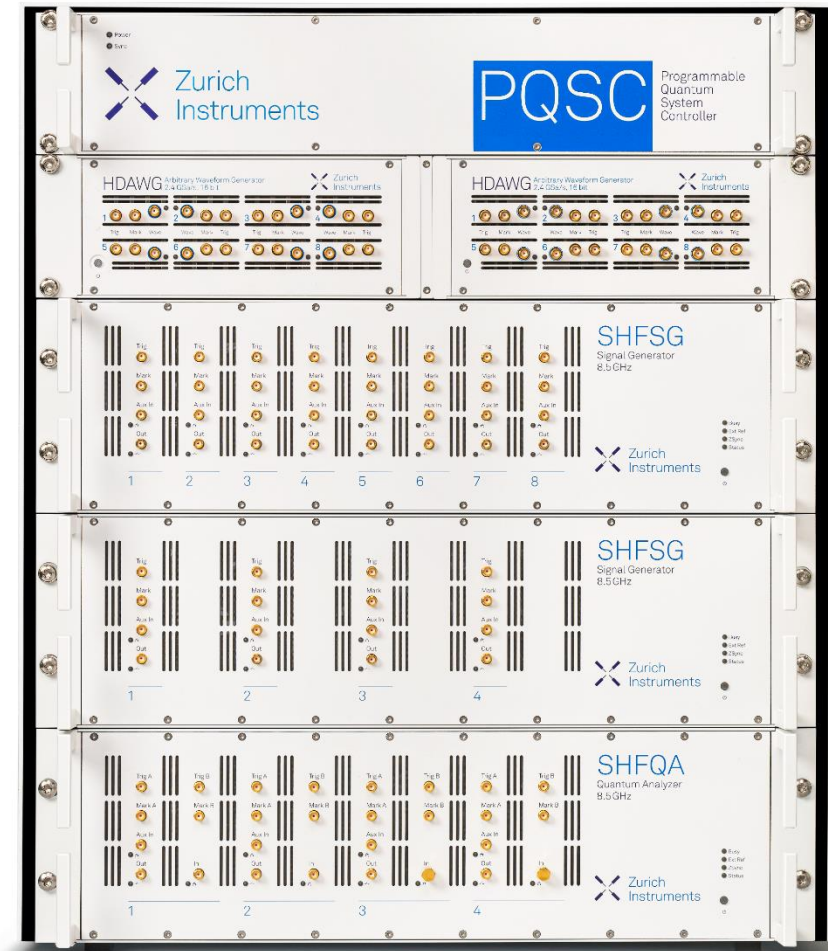

WHY COLLABORATE ON CONTROL ELECTRONICS?

- Control electronics is an Enabling Technology
- It is resource intensive to develop
- Development takes time
- Market is moving fast
- Competition is good
- The whole field benefits from the knowledge exchange

Collaborate with us & we can help you
move faster!

YET ANOTHER QUANTUM EMULATOR

Victor Alessandrini
Maison de la Simulation

victor.alessandrini@cea.fr

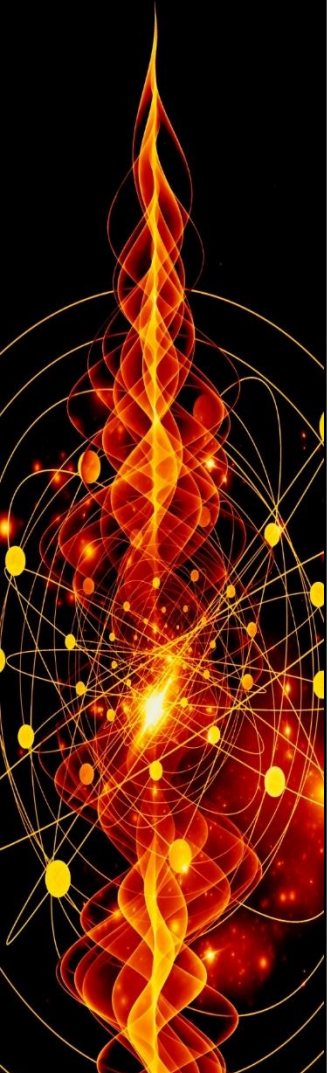

Quantum emulator : purposes

- **PEDAGOGIC** : training tool in algorithmique quantique
- **RESEARCH** : investigation of “use cases” for efficient participation in hybrid contexts, when deep quantum algorithms on the classical side adds substantial value to the simulation.
- Four C++ libraries:
 - **P_Qbits** : shared memory, multithreaded
 - **C_Qbits** : 1 CPU + 1 GPU (native cuda)
 - **D_Qbits** : Multiple CPU, MPI
 - **CD_Qbits** : Multiple (CPU+GPU), cuda aware MPI.

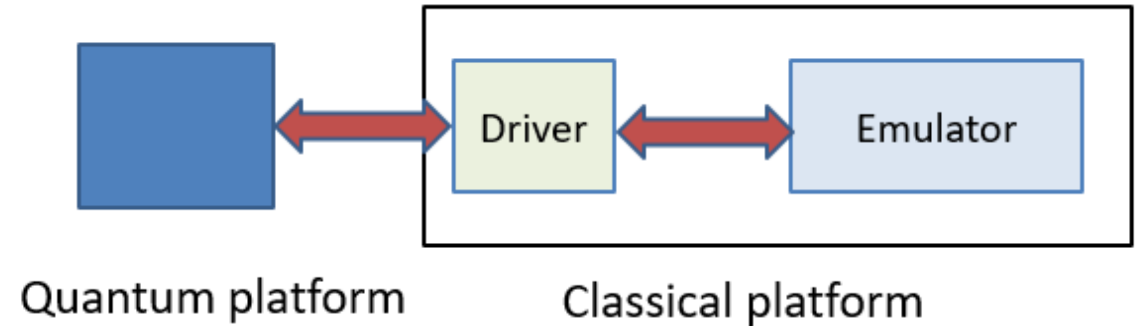

Emulator implements most widely used, high level quantum algorithms. A very detailed documentation is available.

A very large number of test examples, as well as several high level simulations in different areas of science and technology

Performance improvements (besides GPUs)

- Gate fusion : Replacing complex quantum circuits by equivalent multiqubit gates

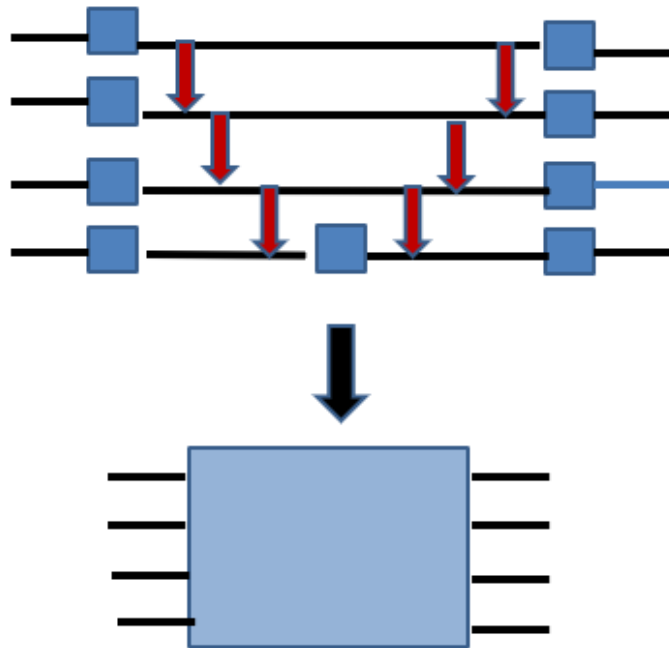

Today, libraries support up to 5 qubit gates.
But algorithms can be extended beyond.

H2 molecule simulation		
Algorithm	CPU	CPU+GPU
Standard circuits	50s	5s
Gate fusion	10s	1s

HUBBARD:

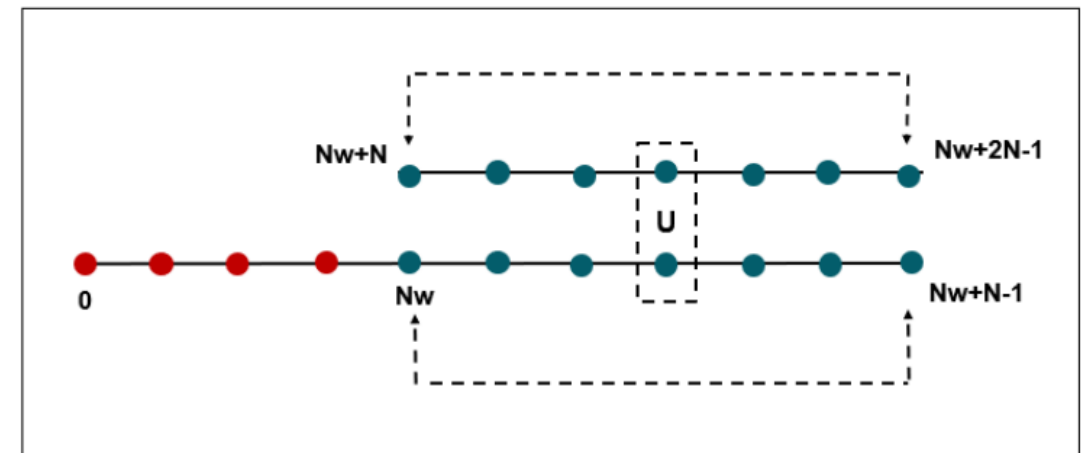
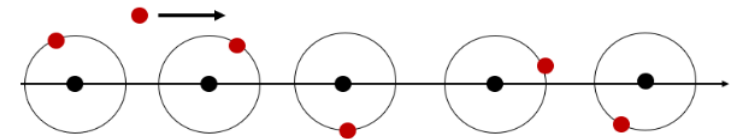

Itinerant ferromagnetism

- **The physics:** ground state at $U=0$

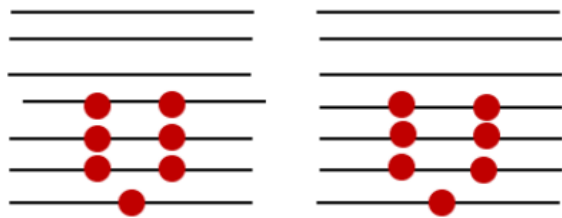

- Flipping spins raises the energy ...

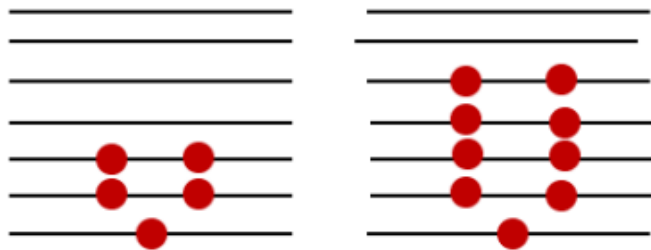

- But, for $U > 0$, there are less pairs of particles face to face, which lowers the energy... Large U will lead to a spin polarized ground state?

OUR SIMULATION: Construct an exact ferromagnetic ground state for large U , and then use Linear Response Theory to study the response to an incoming EM wave (the excitation of spin waves)

We adopt the Variational Eigensolver method, which minimizes the expectation value of the Hamiltonian with trial functions of the form

$$|\Psi_t\rangle = U(\alpha, \beta, \dots) |\Psi_0\rangle$$

where the state vector on the right is a known reference state, initially the exact ground state at $U=0$ obtained with the Givens algorithm.

Trying to go directly to the large values of U ($U > 7$) needed to catch the ferromagnetic ground state is not efficient. Too many variational parameters are required, and we have no way of knowing if the optimizer is returning the global minimum

It is at this point, the emulator running on the classical side enters the game.

The computational protocol.

- *) We use VE to obtain an approximate eigenvector at $U=1$, for example.
- *) Using the emulator software, we apply the Phase Estimate algorithm to the approximate eigenvector, and get information on its projections on the **UNKNOWN EXACT EIGENVECTORS** and on **the EXACT ENERGY EIGENVALUES** associated to them.
- *) If these quality tests are good, we accept the variational result and, using again the emulator software, we emulate an energy measurement, **WHICH FORCES THE COLLAPSE OF THE STATE VECTOR.**
- *) **We end up in this way with the exact ground state at $U=1$**
- *) **Finally, we move the exact $U=1$ ground state to the quantum platform, and replace the reference state. Then, the whole protocol is repeated to compute the exact ground state at $U=2$, and so on and so forth.**

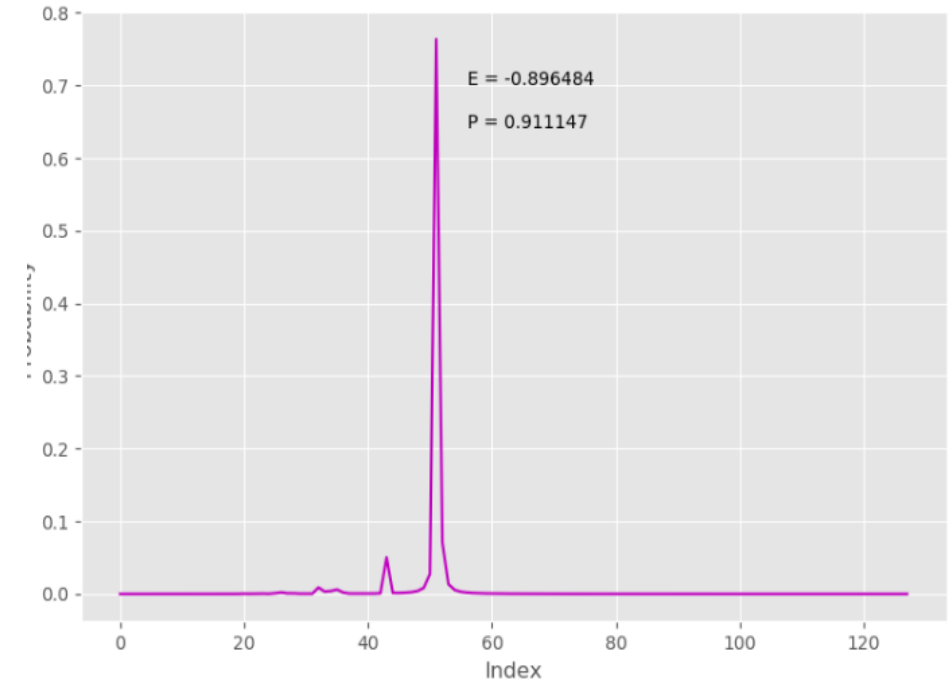

Phase estimate output:

- Energy eigenvalues are derived from the position of peaks
- Peak heights are the probabilities of measuring the associated eigenvalue.



ES

GROUP



WORKING BY YOUR SIDE
TO TACKLE YOUR CRITICAL CHALLENGES

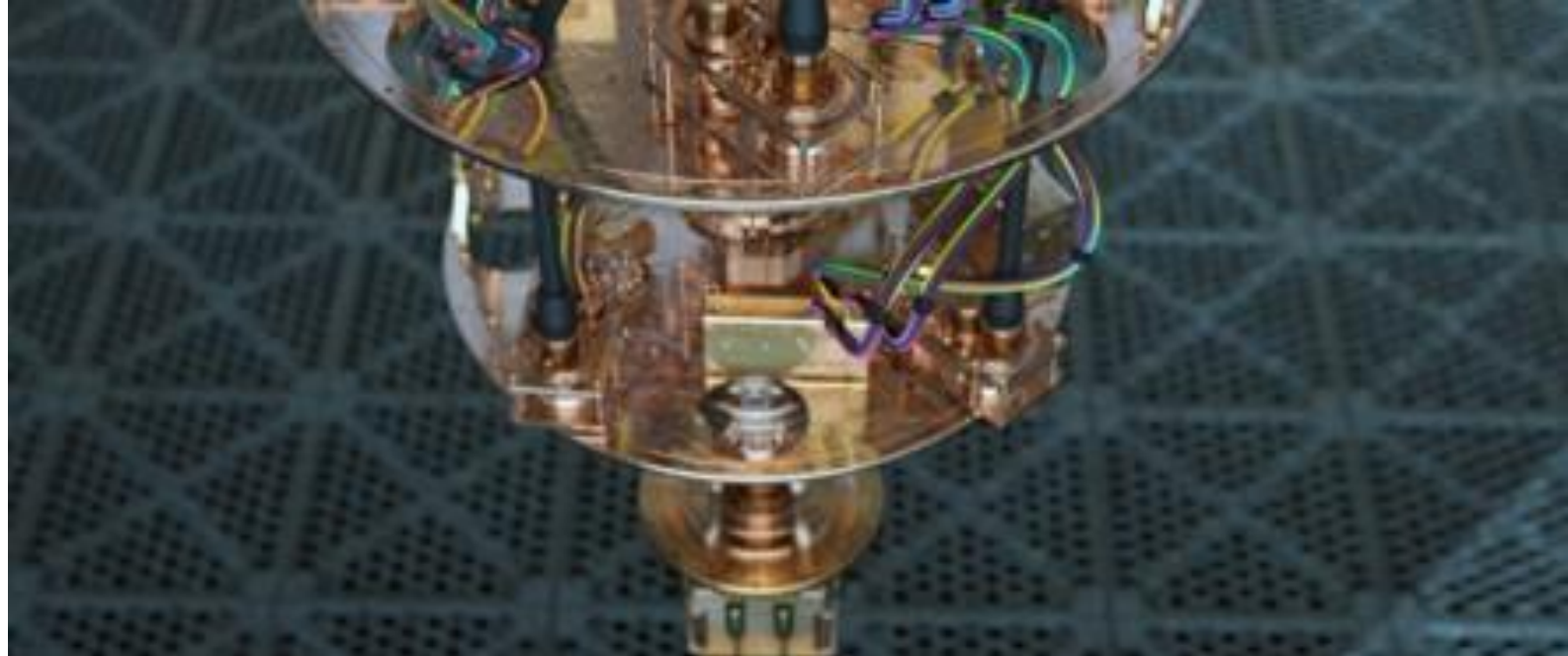

**Journée valorisation
projets quantique**
8 déc 2022

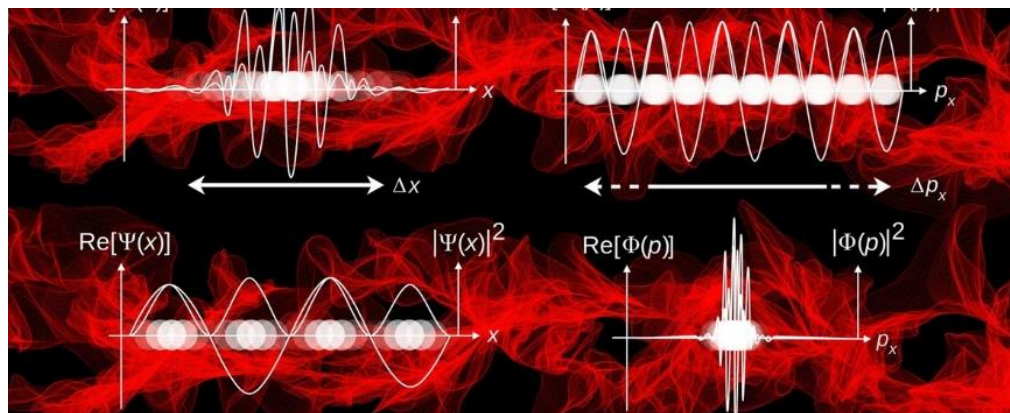



QC4EO project
Quantum Computing for Earth Observation



Investigate whether Quantum Computing can help in solving the problem of unsupervised or weakly supervised machine learning

Applications:

- **Semantic segmentation**
- **Detection of changes to Earth Observation images without in situ data**

QUANTUM MACHINE LEARNING USE CASE

 is a machine learning framework that analyzes satellite images and that wants to use a neural network classifier.



The training times are prohibitive. We investigate whether quantum computing could be a solution.



Technology

Quantum convolutional neural network methods

Quantum convolution circuit



Quantum pooling circuit



QUANTUM LATTICE BOLTZMANN USE CASE



 **ProLB** is a CFD application based on the Lattice-Boltzmann method.

We investigate whether quantum computing can be a solution for:

- large scale acoustic calculations,
- sensitivity analysis of results to changes in parameters
- turbulence calculations.

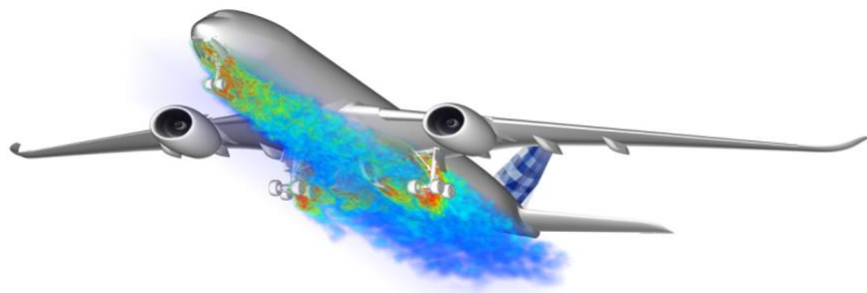

Technologies

Quantum Methods for Partial Differential Equations

Quantum Lattice Boltzmann Method

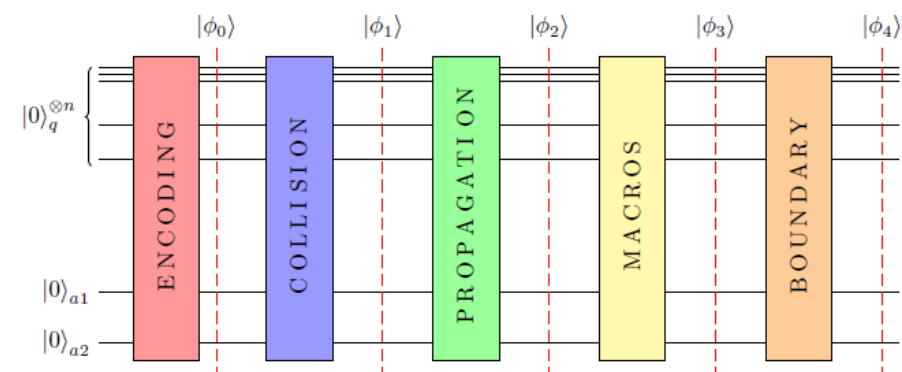

IDÉES DE PROJETS

- Propagation acoustique avec un maillage volumique complet autour des géométries réelles ou fidèles : actuellement, il est impossible de faire des calculs de propagation acoustique à l'échelle d'une ville ou un aéroport.
- Développement de réseaux de neurones quantiques capable à classifier des images satellites sur une grande surface: la taille d'un pays.
- Participer à des consortiums pour les appels à projets
 - Pack Quantique
 - Plan Quantique
 - HORIZON Europe
 - European Defence Fund
- Contactez moi à matthijs.van-waveren@csgroup.eu, si vous êtes intéressé.

The logo features the letters 'CS' in a stylized, white, serif font. The 'C' and 'S' are connected at the bottom, and both have thin, horizontal lines extending outwards from their top curves. The logo is centered within a teal circular background.

CS

GROUP

www.csgroup.eu

*This document is the property of CS GROUP and is confidential.
It may not be reproduced or communicated to a third party without written authorization.*



icon
PHOTONICS

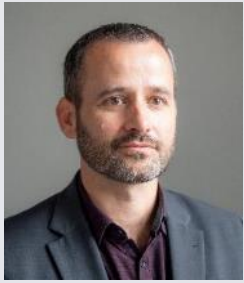

Jean-Luc Polleux
Cofounder & CTO
jean-luc.polleux@icon-photonics.com



Advanced Packaging enabling the Next Generation Optical and Quantum Connectivity

**[3 minutes]
pour convaincre**

ONE TECHNOLOGY. MULTIPLE SOLUTIONS

▶ Wafer-Level Platform

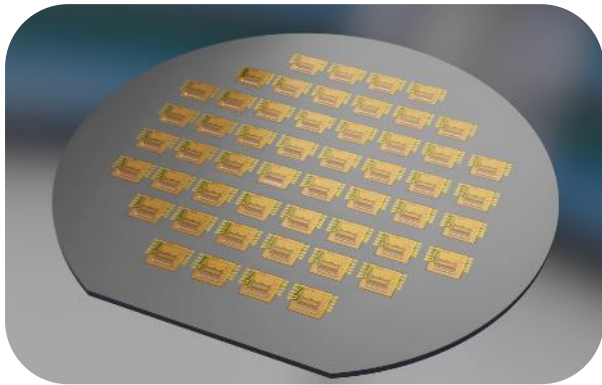

Scalable and mature microfabrication processes: Lithography, Etching, Wafer bonding, Sputtering, etc

▶ Multiple Solutions

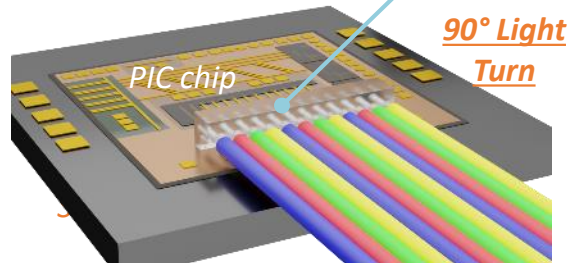
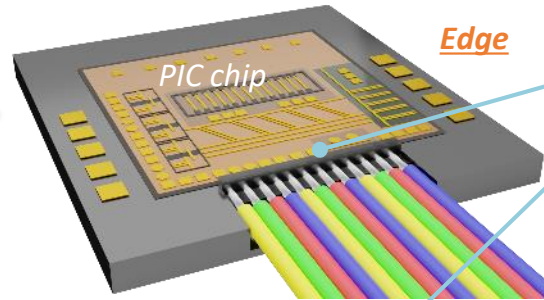
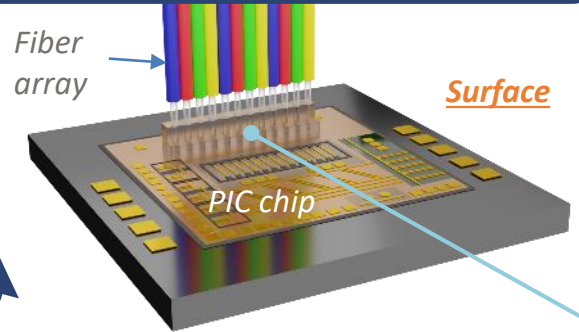

▶ Low loss coupling

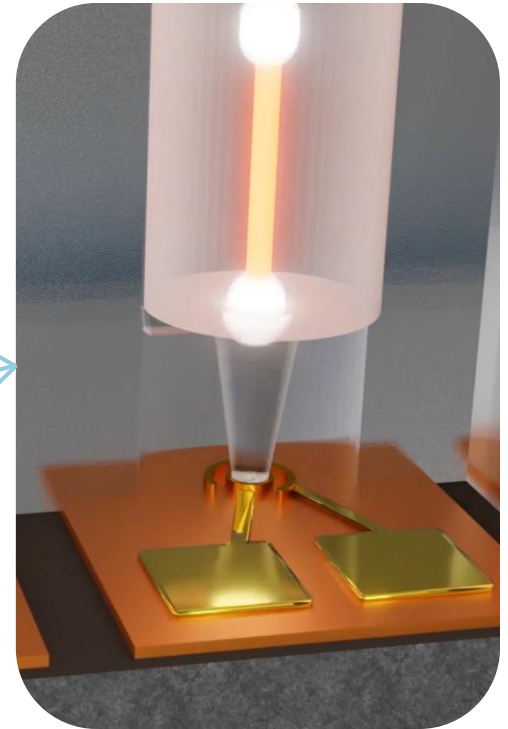

Polymer tapered microoptics

[3 minutes pour convaincre]

USE CASE EXAMPLE

- ▶ Mechanical fixture for Fiber array self-alignment and attachment

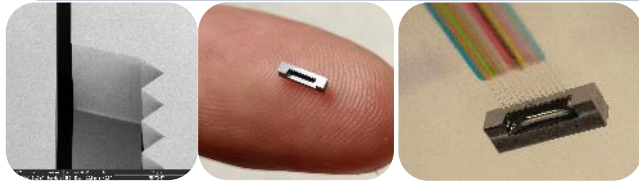

- ▶ Polymer microoptics for low-loss light coupling

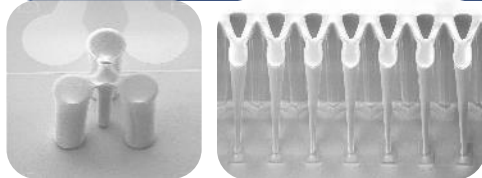

- ▶ Active device embedding: PIC, Detector, SNSPDs, VCSEL, Laser

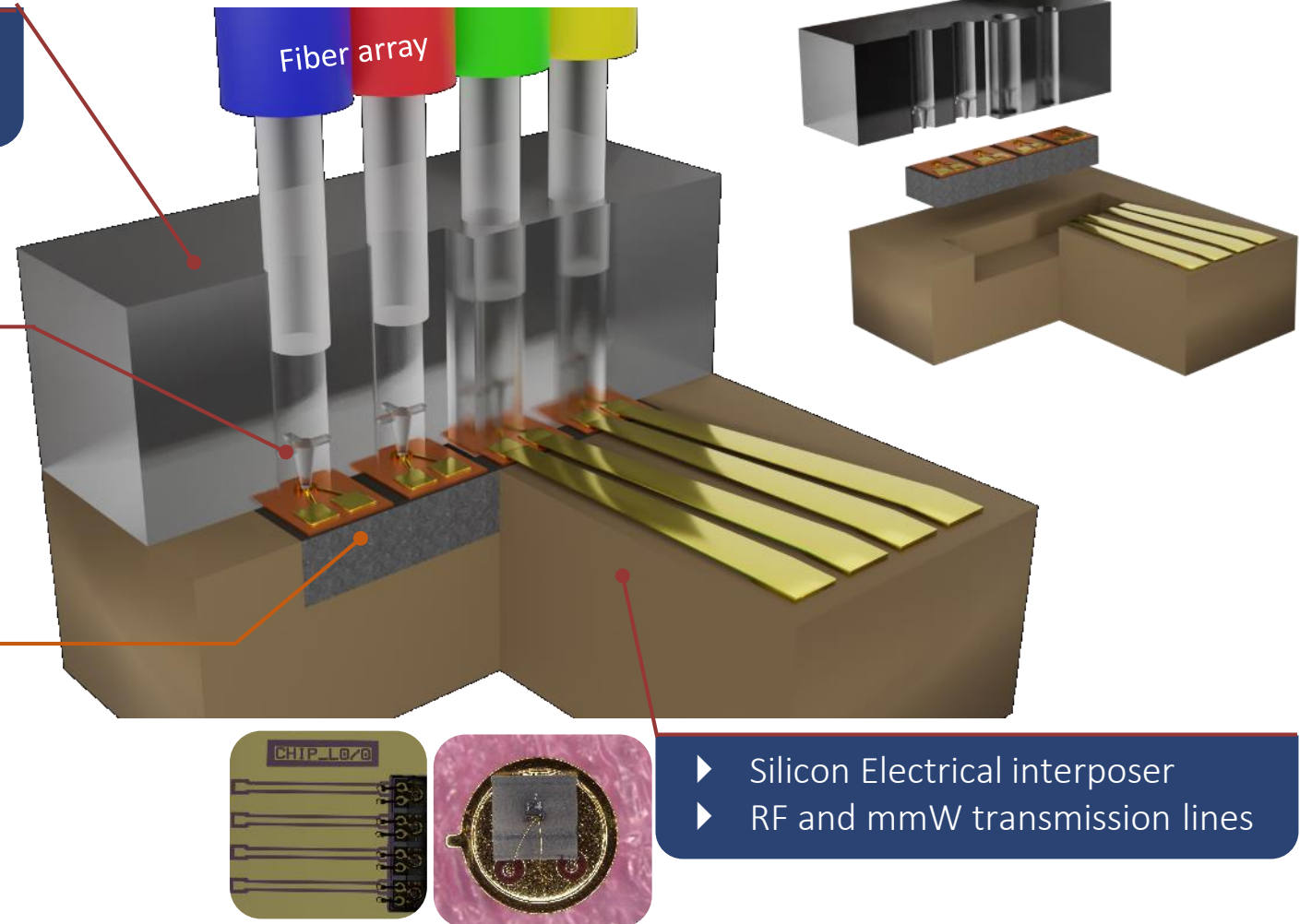
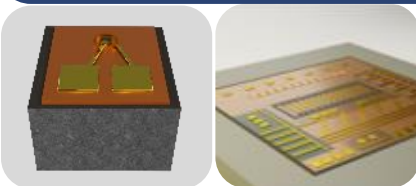

- ▶ Silicon Electrical interposer
- ▶ RF and mmW transmission lines

All-in-one-package

Photonics + Electronics + Mechanics integration

[3 minutes pour convaincre]

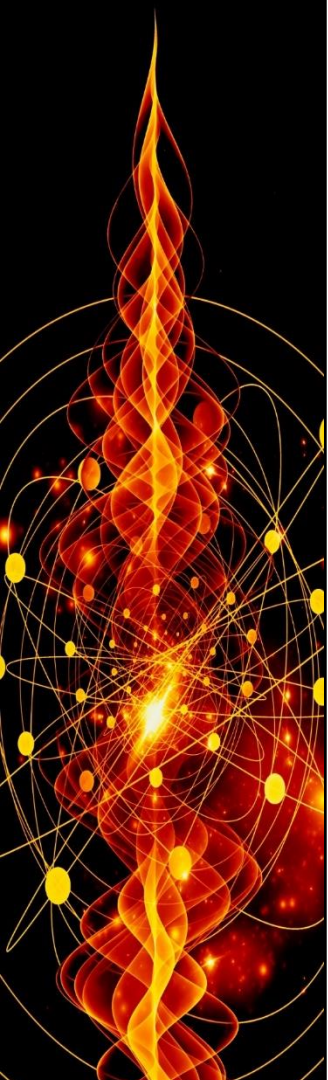

SEDI•ATI

fibres optiques



Apporter la lumière dans votre environnement personnalisé, complexe ou extrême est notre challenge!

LA FIBRE OPTIQUE AU SERVICE DE L'OPTIQUE QUANTIQUE



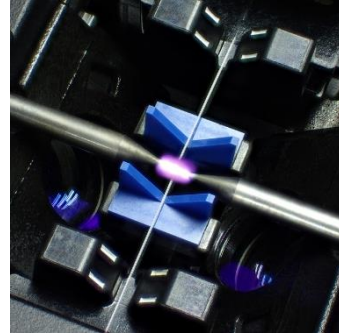
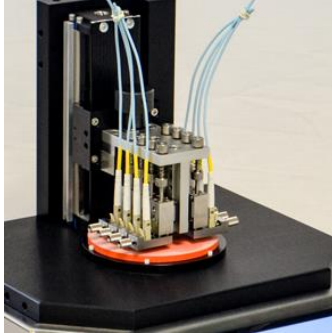

Polissage multiple de fibres optiques (droit, angle...)

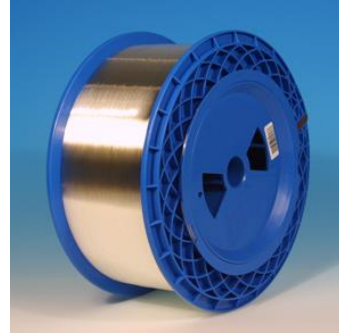
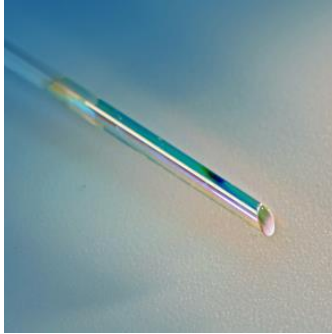

Façonnage de l'extrémité des fibres optiques (polissage et fusion)

Dépôt de couches minces (métallisation, traitement anti-reflet, filtres...)

Collage, brasage, enverrage, fusion



Bobinage

Conception de mécanique spécifique dédiée à la fibre optique

[Milieux cryogéniques]

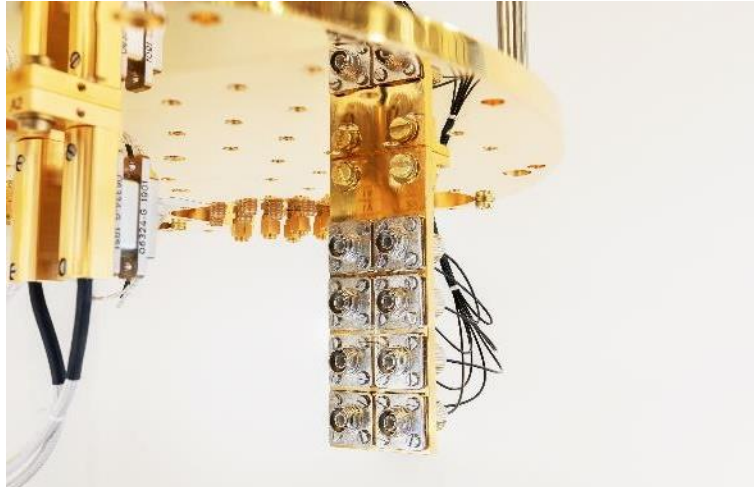

Spectroscopie optique avec un cryostat où la température de l'échantillon est $< 1,5$ K

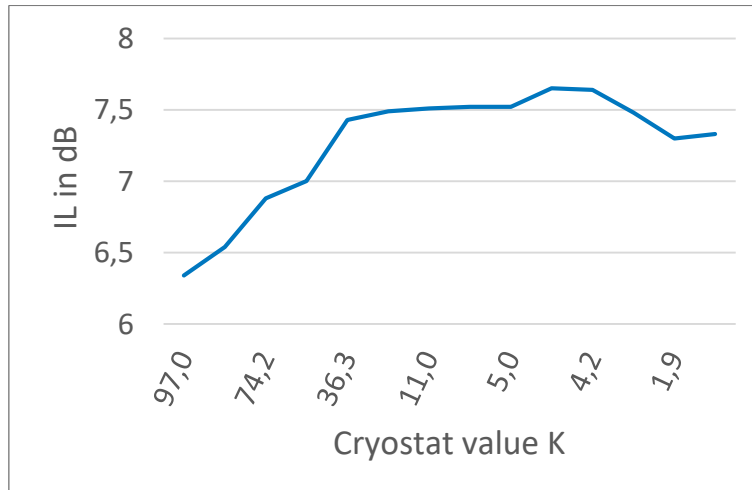

Variation des pertes d'insertion dans le cryostat

13/12/2022

Le challenge

Liaisons fibres optiques fonctionnant à l'intérieur d'un cryostat dans des environnements à très basse température et sous vide poussé.

- froid cryogénique : inférieur à 0,5 K (-272,65 °C)
- vide poussé : 10^{-11} mbar

Spécifications techniques

Cryostat	de 0,5 K (-272,65 °C) à 3 K (-270,15 °C)
Structure	mono-fibre ou bundle
Type de fibre	monomode ou multimode avec revêtement polyimide
Liaison fibre/férule	scellement
Connecteurs	SMA, FC, ST, E2000 APC, LC, MT...
Type de gaine / tube	tube inox; \varnothing variable selon la structure du câble (mono-fibre ou bundle)
Bride pour enceinte cryostat	selon la demande du client; M10, KF DN16, KF DN40...
Longueur de fibre dans le cryostat	1,5 m max.
Herméticité	$> 10^{-8}$ mbar.l/s

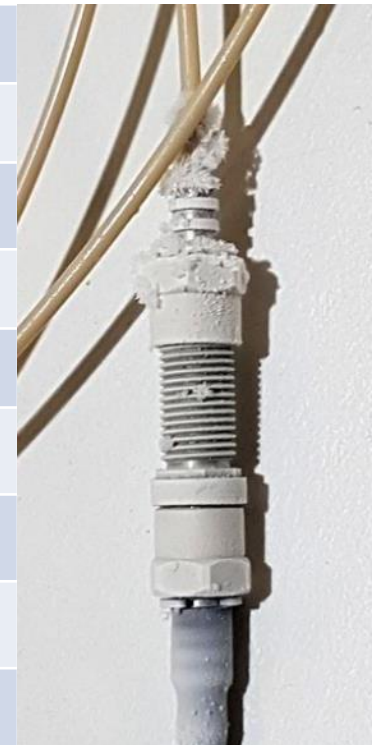

Dr. Sofiane BAHBAH

202

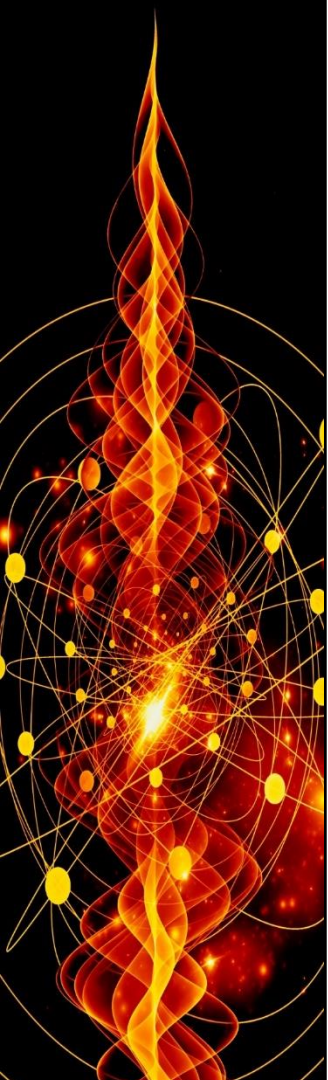

THALES
Building a future we can all trust



THALES

Building a future we can all trust



Quantum Computing & Algorithms

Thales Research & Technology, France

www.thalesgroup.com

Markets we serve



AEROSPACE

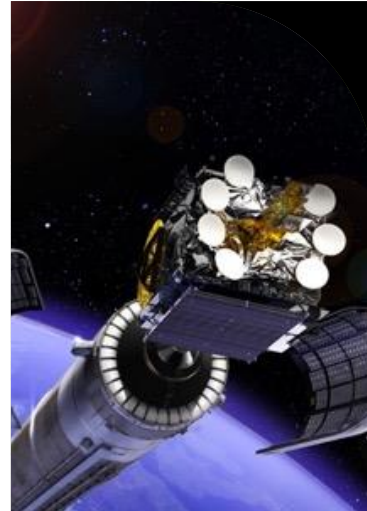

SPACE



GROUND
TRANSPORTATION



DEFENCE

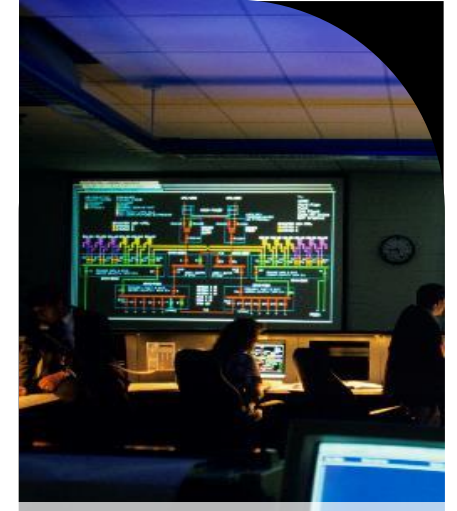

SECURITY

Need of physics simulation (offline) and real-time processing for safety-critical systems (online)

[3 minutes pour convaincre]

TRT-FR addresses QC with industrial constraints

Main challenges

- Characterization of available QPUs and simulators
 - Benchmarking
- Algorithms Coding with industrial constraints
 - Optimization (scheduling, mission planning)
 - Deterministic methods (electromagnetic simulations)
 - Monte Carlo methods (path planning, electromagnetic simulations)
- Identification of relevant algorithms, SW & tools
- Coding with French quantum computing machines
- Scale-out projection for real use-case Thales applications

Existing roadblocks

- Limited number of hardware resources for NISQ & LSQ HW to answer Thales applications' needs
- Variety of SW, languages, tools and quantum paradigms
- Accessibility to QPUs and Hybrid HPC



ALICE & BOB



XANADU



PASQAL



D:wave
The Quantum Computing Company™

[3 minutes pour convaincre]

What do we need to succeed?

Quantum algorithms

- Leverage elementary algorithmic bricks
 - To propose new algorithms adapted to our needs
 - Adapt algorithms' hypothesis to match the problem's constraints
- Estimate the resources needed
 - Overhead of error correction
 - Overhead of compilation

Quantum physics

- Understand how information is encoded in a physical system
 - To properly encode the problem of interest
 - To derive noise models for targeted hardware architectures

Simulations

- Running intensive simulations on HPC clusters
 - To gain intuition on the algorithm
 - To test on simplified models



THALES

Building a future we can all trust



Thank you.

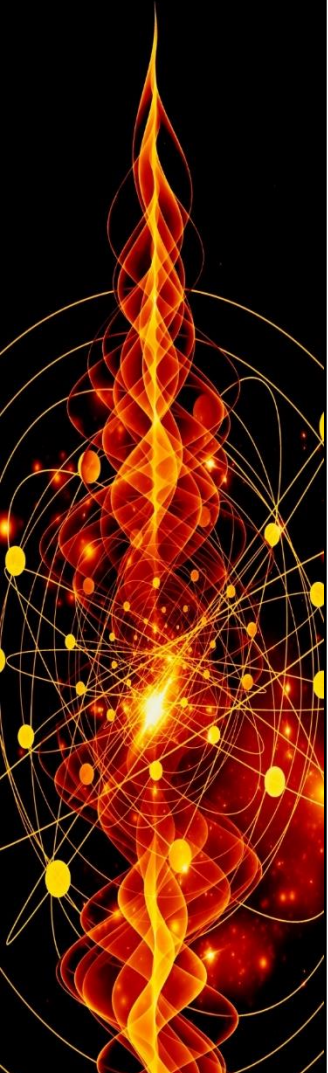

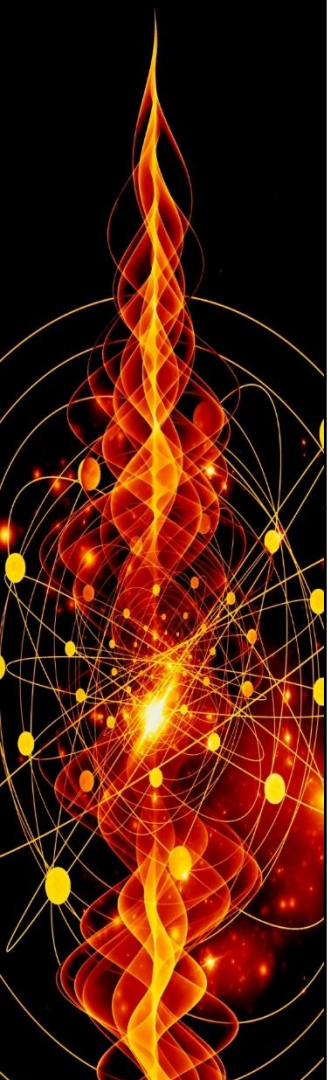

UNIVERSITÉ
Clermont Auvergne



C. Prodhon



P. Lacomme



E. Bourreau



M. Sevaux

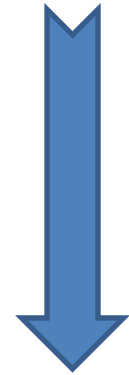

Novembre 2021 : Ecole quantique
à Montpellier (61 personnes)
Mai 2022 : Journée quantique
à Clermont-Ferrand (25 personnes)
Avril 2023 :
Événement international à Troyes

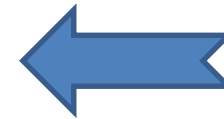

Objectifs :

- promouvoir l'optimisation quantique
- animer la communauté
- favoriser l'apprentissage du quantique

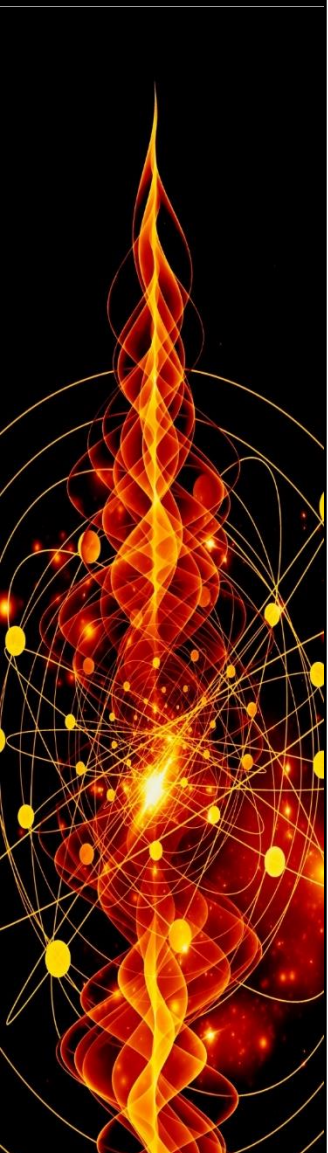

This event received financial support and help from the following organizations :



21th EU/ME meeting x Quantum School

Emerging optimization methods: from metaheuristics to quantum metaheuristics

Troyes 17th - 21th april 2023

13 minutes pour convaincre

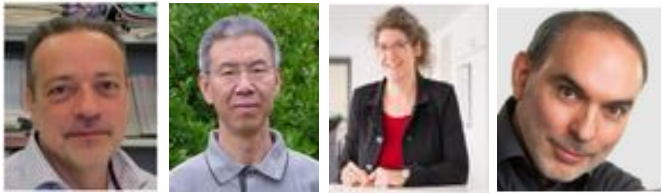

Special session on Metaheuristics of the META Working. Chairman: [Laurent Deroussi](#)

Special session of the GT Origin on Metaheuristic for scheduling problems. Chairman: [M.-A. Manier](#) , [D. Lemoine](#) and [N. Grangeon](#) .

Special session of the GdT OR on "Optimization of smart grids" - Chairman: [Sonia Vanier](#) and [Nancy Perrot](#) - Room A3

Anita Schöbel : présidente de EURO

Olivier Ezratty, Simon Perdrix, Jin-Kao Hao, Eric Taillard, Olivier Hess, Christophe Couteau, Jean-Michel Torres, , **Fred Glover**....

[3 minutes pour convaincre]

Participer ?

Soumettre des travaux
de recherche (partie conférence)



15h00-16h30: Special session of the GT ROQ. Chairmain : [Wesley Coelho](#) and [Hnaïen Faïcel](#) - Room A3

: The objective of this session is to present the studies in purely quantum optimization or hybrid optimization (quantum/classical). We recommend work completed or in progress, feedback on successful initiatives or unsuccessful experiments. The session seeks also all the studies of comparisons of different quantum platforms (D-wave, PASQAL, IBM,...)

17h00-18h30 : Special session on Quantum Meta Heuristic Application. Chairman: [Joseph Mikael](#), Pascale Bendotti from EDF R&D. Room A1

: Both Quantum Annealing based algorithms and variationnals based algorithm (QAOA, RQAOA) should be considered as a new class of meta-heuristics and numerous researches are now directed on such methods and on applications. This session will host papers on the following topics:

Assister pour s'informer



O. Ezratti



S. Tanzilli



H. Ollivier

Assister pour découvrir le quantique



O. Hess (ATOS)



JM Torres (IBM)



W. Coelho

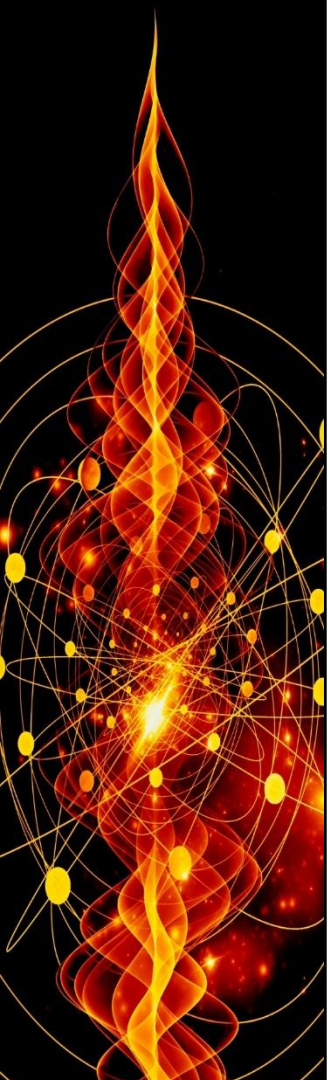

viathor

QPU CONTROL & READOUT FIDELITY

Noise

Functional but poor
Microwaves performance
limits Fidelity



Wiring Nightmare

Thousands of cables drawing
heat through the cryostat



Expensive Cost

25 to 100 k€ and 50 W min
per Qubit



25 YEARS TRACK RECORD EXPERIENCE



Know-How
25 years of
Microwaves
Applications

Production
Sell each year
an iterative
solution

Metrology
Calibration,
Signal
Processing

ISO 9001
Been there,
done that

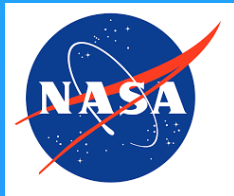

Low-Noise
State of the Art
expertise

Support
USA, India &
China local
partners

Software
Embedded
and GUI
coding

Timing
Atomic Clocks
Frequency
Stability test

Intl. Growth
Proven 90%
past exports



MULTIPLEX MANY HIGH FIDELITY SIGNALS

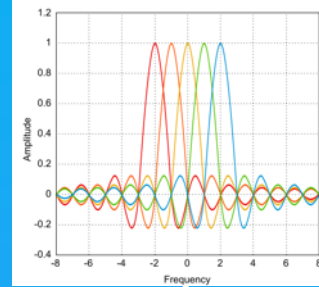
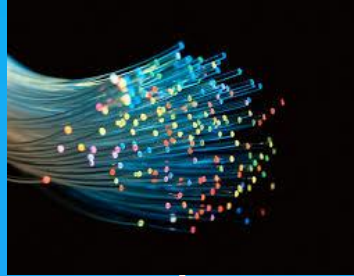

CABLES

Remove 99%
of the coax
cables

Use Optical
Fiber

TECHNOLOGY

Multiplex Qubit
over Pure
Microwave
Signals

Cleaner with
less hardware

COST & ENERGY

Divide the cost
by 5000

Divide the
Energy
consumption by
100



« Présentation idées de projets »

- **Université de Clermont-Ferrand** : Philippe Lacomme
- **Warnery** : Antoine Warnery



[5 minutes
pour convaincre]

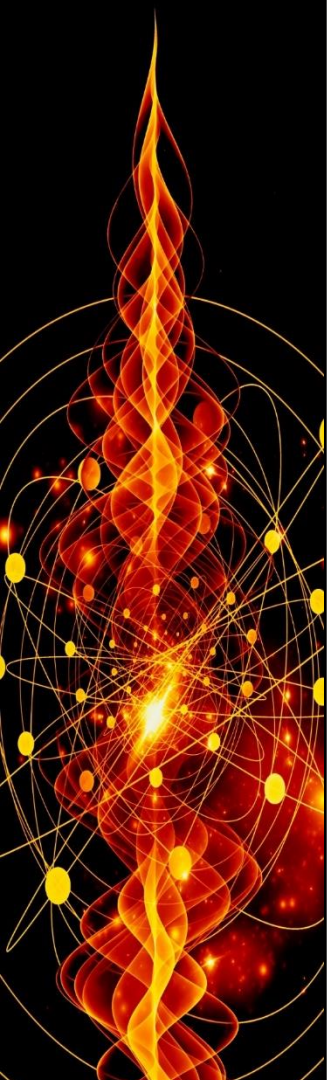

UNIVERSITÉ
Clermont Auvergne

RECHERCHE OPÉRATIONNELLE QUANTIQUE

Porteurs du projet : Caroline Prodhon et Philippe Lacomme

Motivation :

Recherche opérationnelle → résolution de problème coûteux en temps de calcul

Beaucoup de problèmes viennent de la Chaîne Logistique

- création de planning
- transport de marchandises

Problèmes de NP

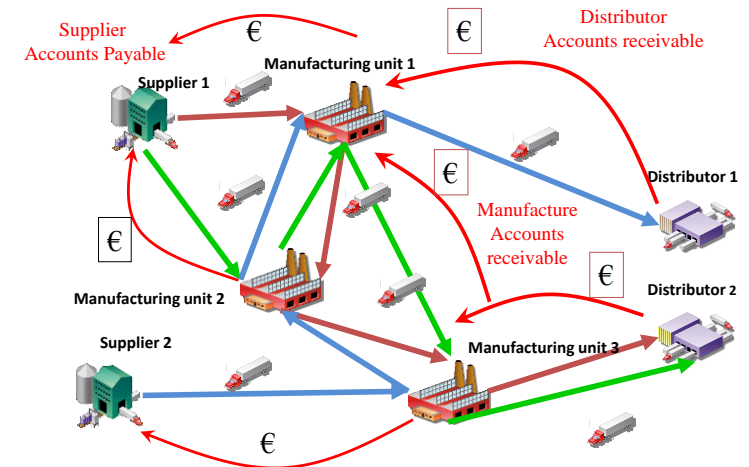

Difficulté :

Ordonnancement de 10 lots de pièces sur 10 usines
 10^{80} solutions \rightarrow énumération $\rightarrow 10^{40}$ secondes

Questions de recherche :

Savoir définir les Hamiltoniens associés
aux problèmes de RO

S. Hadfield et al, From Quantum Approximate Optimization Algorithm to a Quantum Alternating Operator Ansatz. Algorithms 12.2 (2019). <https://arxiv.org/abs/1709.03489>

Définir de nouvelles approches de type QAOA

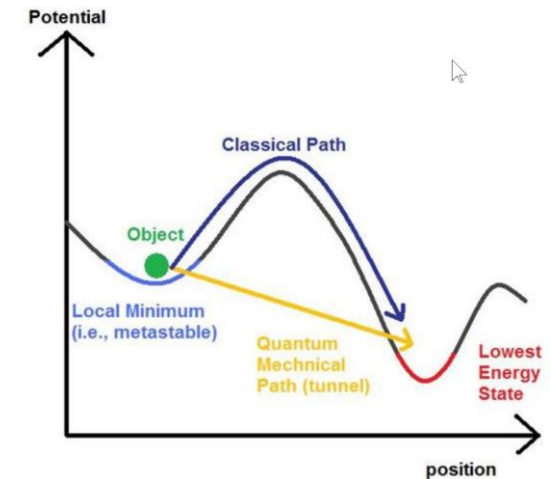
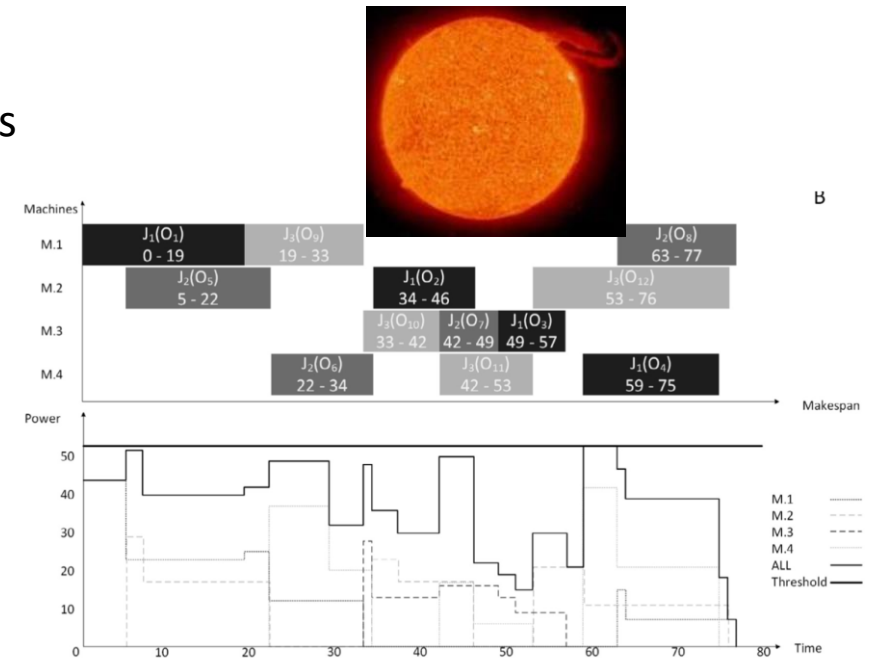

TRAVAIL SUR UN HORIZON DE 4-5 ANS

Résultats en cours

E. Bourreau, G. Fleury et **P. Lacomme**. Introduction à l'informatique quantique. Avril 2022. Ed. Eyrolles

G. [Fleury](#) and [P. Lacomme](#). Description of the Grover algorithm based on geometric considerations [arXiv:2210.16809](#)

G. [Fleury](#) and [P. Lacomme](#). Mixer Hamiltonian with QAOA for Max k-coloring : numerical evaluations [arXiv:2207.11520](#)

G. [Fleury](#) and [P. Lacomme](#). Adiabatic based Algorithm for SAT: a comprehensive algorithmic description [arXiv:2207.09984](#)

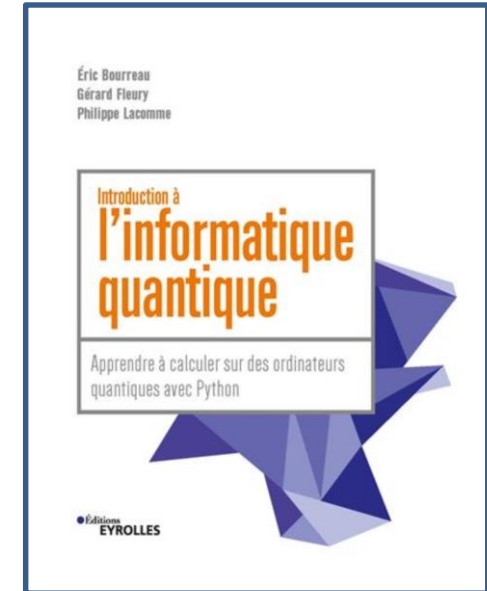

TRAVAIL SUR UN HORIZON DE 4-5 ANS

Projets sur 4 ans

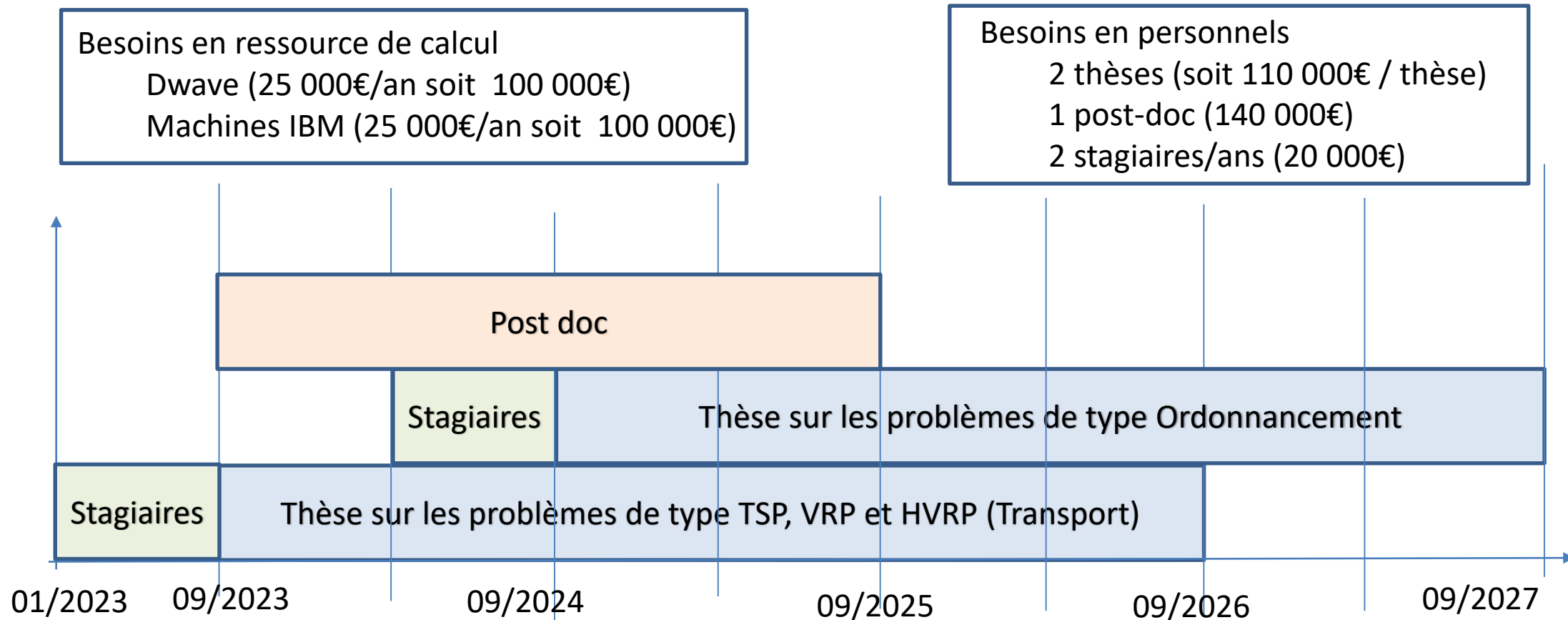

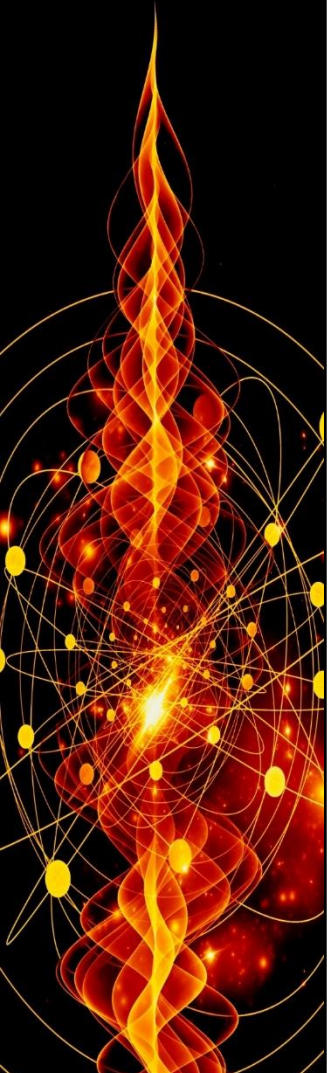

ANTOINE WARNERY

Projet : Dynamique quantique

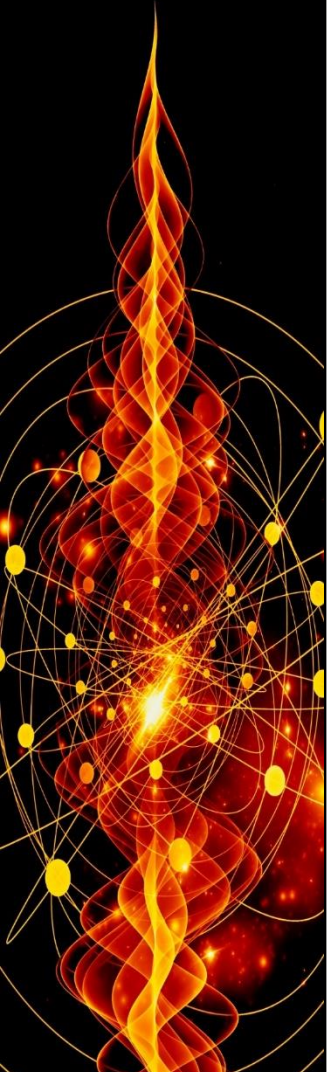

- La modélisation de structures nucléaires permet la visualisation, la manipulation et la prédiction de comportement réaliste de propriétés atomiques, quantiques, physiques et chimiques

EUE ÉDITIONS
UNIVERSITAIRES
EUROPÉENNES

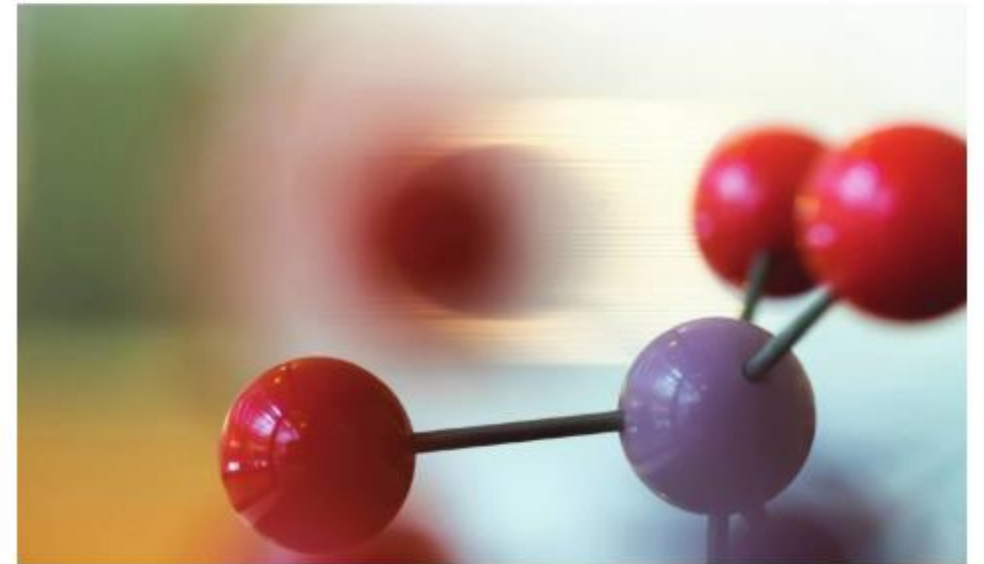

Antoine Warnery

Structures nucléaires

Une approche de la physique classique

Modèle graphique

Le modèle graphique représente

les nombres quantiques,
(le nombre quantique principal, le nombre
quantique secondaire, le nombre quantique
magnétique, le spin)

Les propriétés chimiques
(le nombre d'électrons de valence, le nombre
d'oxydation, ...)

Les propriétés physiques
(Les propriétés optiques, électriques,
interactions, gravité, ...)

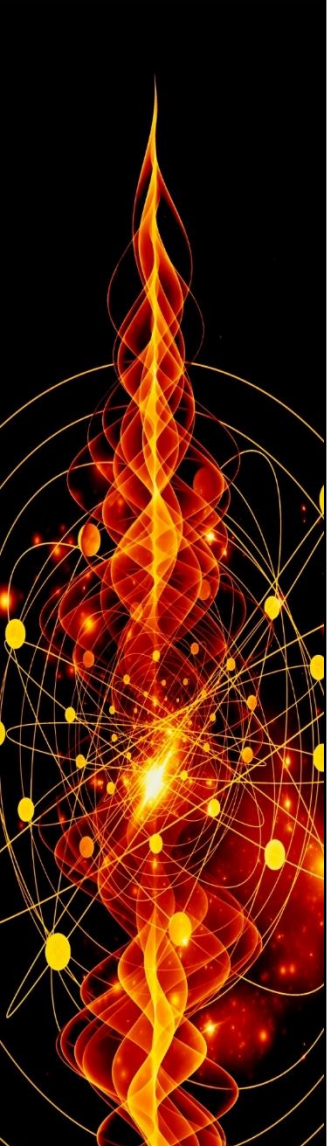
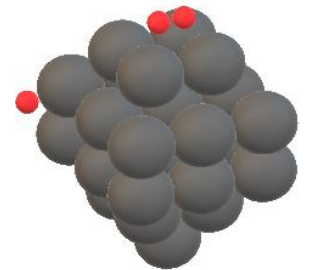
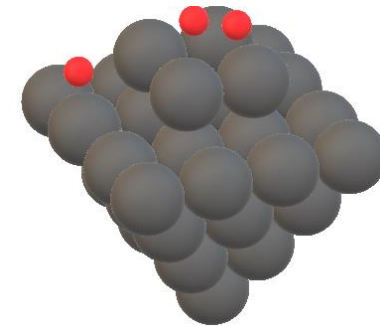
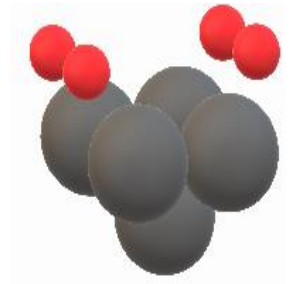
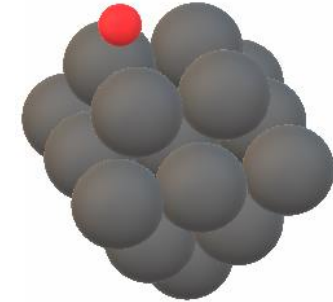

Modèle numérique

Le modèle numérique prédit en fonction du nombre de protons, et de la position :

- le nombre quantique principal,
- le nombre quantique secondaire,
- le nombre quantique magnétique,
- le nombre de spin,
- le nombre d'électrons de valence,
- le nombre d'oxydation,
- la règle de valence,
- ...

Exemple de modèle :

C(1,2/1+4), Si(1,2,2/1+4),
Ge(1,2,3,2/1+4), Sn(1,2,3,3,2/1+4),
Pb(1,2,3,4,3,2/1+4).

Hydrogénoïde :

H(1/0+1), Li(1,1/0+1),
Na(1,2,1/0+1), K(1,2,2,1/0+1),
Rb(1,2,3,2,1/0+1).

Métaux de transition :

Co(1,2,3/2,1+9), Rh(1,2,3,3/2,1+9),
Ir(1,2,4,3/2,1+9)

Lanthanide, actinide :

Nd(1,2,3,4/3,2,1+6),
U(1,2,3,4,4/3,2,1+6)

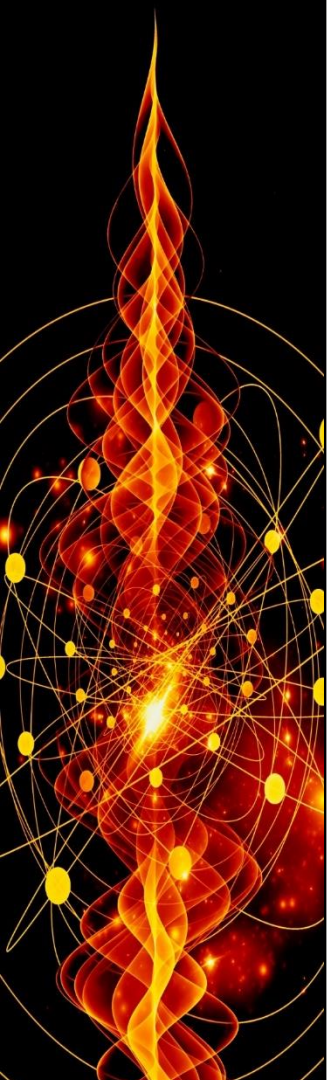

Projet mécanique et dynamique nucléaire

Le but est d'appliquer les équations de la mécanique classique aux structures nucléaires notamment pour modéliser le déplacement des protons sur les atomes afin de décrire des phénomènes de la physique quantique.

- Phénomènes optiques,
- Phénomènes électriques,
- Phénomènes de la semiconduction.

Recherche de partenaires institutionnels ou privés ayant des capacités de calculs et de simulation numérique.

Contact : Antoine Warnery - warneryantoine@free.fr

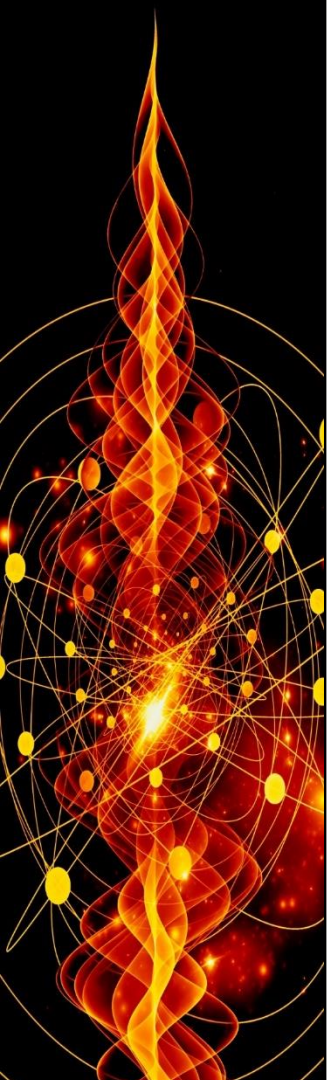

[Conclusion]

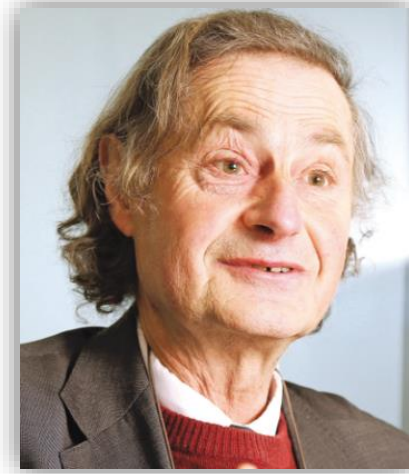

Christian Saguez
Président d'Honneur
Teratec